



LAMY
RHEOLOGY
INSTRUMENTS

USING MANUAL

RM 200 CP4000 PLUS

VERSION N° RM2CP4K-UK06/2025



TABLE OF CONTENTS

1	INTRODUCTION	4
1.1	Components	5
1.2	General view of your device	6
1.3	Connections	9
1.4	Specifications	10
1.5	Installation	11
2	GETTING STARTED	12
2.1	State icons	12
2.2	Main Menu	12
2.3	Measure menu	13
2.3.1	Manual measure mode	13
2.3.2	Automatic measure mode	15
2.4	View results menu	19
2.4.1	Show results	20
2.4.2	Export results	20
2.4.3	Delete results	21
2.5	Zero setting	22
2.6	Parameters menu	23
2.6.1	Languages	23
2.6.2	Date / Hour	24
2.6.3	Sounds/Standby/Lighting	24
2.6.4	User Name	25
2.6.5	Units/Density	26
2.6.6	Measuring System	26
2.6.7	Locked Mode	29
2.6.8	Torque range	29
2.6.9	Miscellaneous	30
2.6.10	LIMS mode	30
2.6.11	Printing	31
2.6.12	Service	31
2.7	Remote mode menu	31
2.8	Programs menu	32
2.8.1	Create new program	32
2.8.2	Edit program	38
2.8.3	Delete program	38
2.9	Temperature setpoint menu	38
3	MEASURING WITH YOUR DEVICE	39
3.1	Installation of measuring system	39
3.2	Temperature settings	40
3.3	Gap settings	41
3.4	MS CP/MS-PP	43
3.5	MS DINS (models N240256 and N240257)	44
3.6	MS SV (models N240256 and N240257)	47
3.7	MS-VANES (models N240256 and N240257)	50
4	VERIFICATION OF YOUR DEVICE	50

1 INTRODUCTION

The instrument is a device able to measure the viscosity, which is capacity of a product to resist to the flow.

The fluid is forced to a shear rate (rotational speed) and the shear stress (motor torque) is measured. The values of shear rate and shear stress then make it possible to calculate the viscosity using the Newton equation and the constants associated with the mobile used.

$$\text{Equation of Newton is: } \eta = \frac{\tau}{\dot{\gamma}}$$

With η for viscosity in Pa.s, τ for shear stress in Pa and $\dot{\gamma}$ for shear rate in s⁻¹.

Shear stress and shear rate are calculated by using constants of each measuring system as:

$$\tau = M \times K_{\text{Tau}} \text{ with } M \text{ for motor torque in mNm and } K_{\text{Tau}} \text{ in Pa/mNm.}$$

$$\dot{\gamma} = n \times K_D \text{ with } n \text{ for rotational speed in rpm and } K_D \text{ in s}^{-1}/\text{rpm.}$$

The instrument calculates the viscosity by dividing the shear stress by the shear rate for each measuring point. The K_{Tau} and K_D constants used depend on the measuring system selected for the measurement.

Viscosity depends on the temperature, then it must be essential that all viscosity values are associated to a reading of the sample temperature, in order to compare viscosity for different samples.

There are some products for which the viscosity, to a constant temperature, stay unchanged, even if we change the shear rate. Those samples are named **Newtonian fluids**, i.e. : Oils, Water, Glycerol, etc...However, many substances have a variation of viscosity in function of speed of shearing, and the Flow Behaviour of those samples could be determined with measuring instruments able to set many speeds of rotation.

The instrument is constituted with a continuous current motor with an optical encoder, in order to warranty a great accuracy of the speed of rotation of bob, on all torque range.

The instrument has an easy touch screen display, on which you could read the **speed, measuring spindle reference, temperature, the measured torque and the dynamic viscosity in mPa.s (=cPois) or Pa.s.**

The instrument can be used with different measuring system. You will find below a list of compatible measuring system with this instrument.

- **MS CP:** Measuring systems cone or plate compatible with DIN 53019 / ISO 3219 / ASTM D4278-D7395 (316L Stainless Steel). These systems make it possible to set the shear rate in order to carry out viscosity measurements or to obtain curves to study flow behaviour, yield stress or thixotropy. They are particularly suitable for measurements on very small quantities for control or development of homogeneous products with or without particles (size <100µm), guaranteeing easy cleaning.

Models N240256 and N240257 can use these following measuring system

- **MS DIN:** Coaxial cylinders measuring systems according to DIN / ISO 3219 (316L stainless steel). These systems make it possible to set the shear rate in order to carry out viscosity measurements or to obtain curves to study flow behaviour, yield stress or thixotropy. They are particularly suitable for the control or development of homogeneous products with liquid aspect and with or without particles (size <200µm).

- **MS SV:** Measuring systems for low volumes (316L stainless steel). These systems, unlike the MS-ASTM and MS-DIN systems, make it possible to measure products in small quantities by applying a shear rate up to temperatures of 200 ° C (according to models, see table). With RT1, these systems are compatible with ASTM D3236 or D4402.

- **MS VANE:** Measuring spindles with blades (316L stainless steel). These systems are ideal for viscosity measurement (value or curve) in control or development of all types of products even of very high viscosity with or without particles (size <5mm). They can be used for direct measurement in user's containers or in tubes of MS-DIN systems.

1.1 Components

Rheometer is delivered inside a foam protection to avoid any problem during transport. RM200 CP4000 PLUS is delivered mounted. You will find some cable, measuring system (according to order) and some tools for installation and using.



RM200 CP4000 PLUS



Cable and power supply for measuring head



Cable for CP4000



Tool for levelling of RM200 CP4000 PLUS



Level indicator

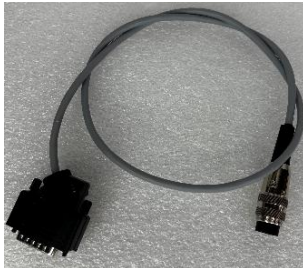

Cable for connexion of measuring head with CP4000 temperature control.



Cable for connexion of measuring head with CP4000 for lift control (only models N240251, N240257, N240601, N240801 and N240901).



Cable for CP4000 lift



Pipe with connector for liquid Peltier (only models N240800 and N240801).



Bottom plate 70 mm (excepted models N240256 and N240257).

For models N240256 and N240257, please find above additional items included with device.

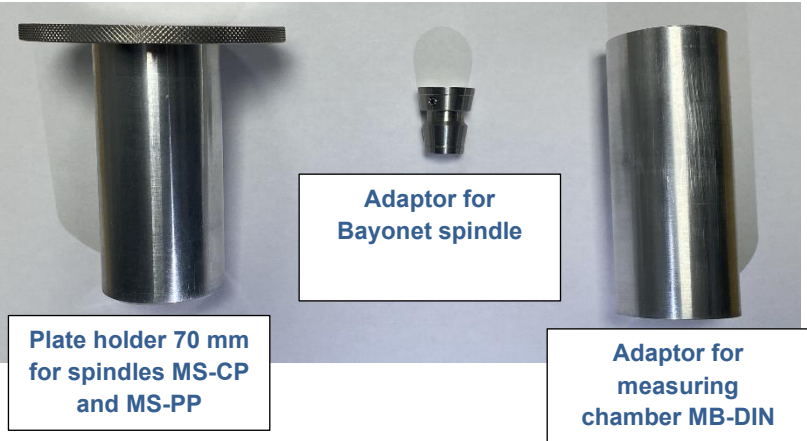

1.2 General view of your device

Once your device will be mounted and installed, it looks like this:

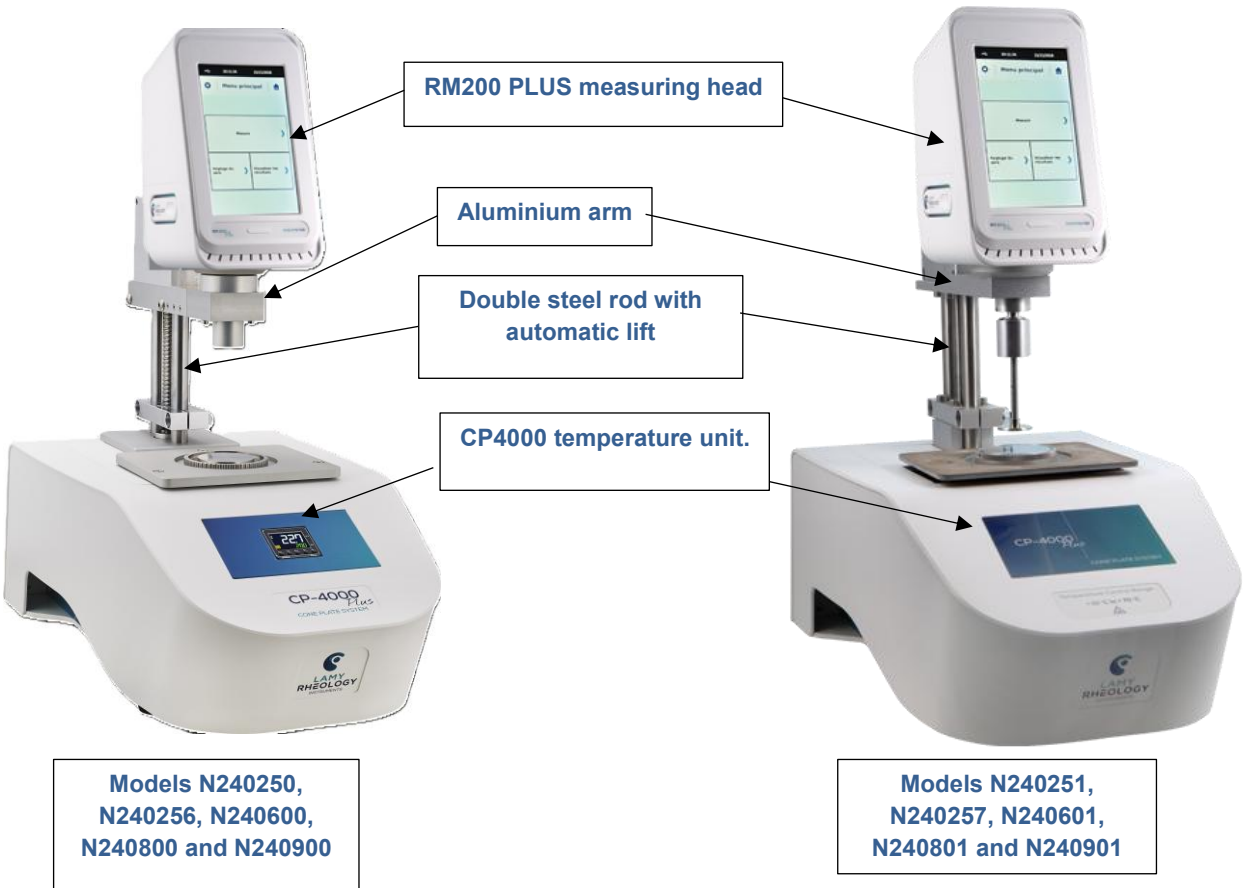

- **TOUCH Screen**

The new PLUS series is equipped with a 7" colour touch screen. It gives you greater working comfort and a clearer view of your data and analysis results.

- **On / Off switch**

Always with the aim of improving your experience, LAMY RHEOLOGY has decided to equip its entire range PLUS with an On/Off button. It has been placed on the back of the device for greater intuitiveness.

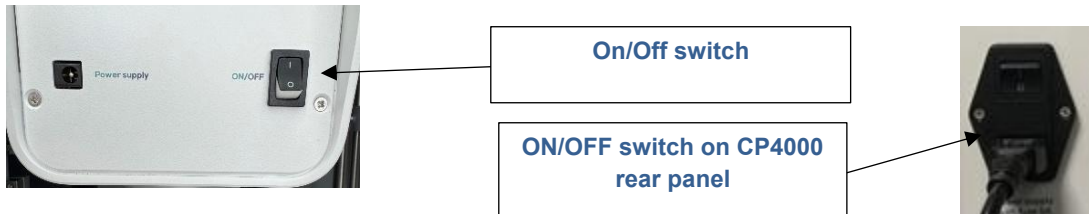

- **Aluminium arm**

The measuring head is fixed to the arm with tow screw.

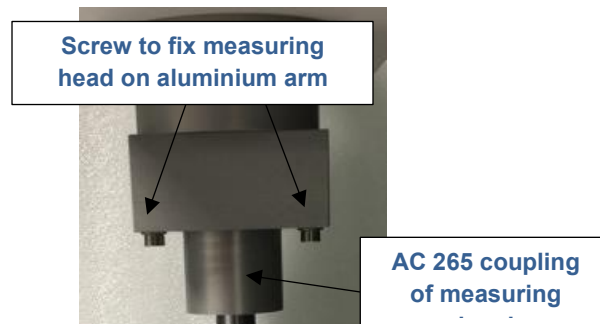

- **Stainless steel rod**

The support rod is made of stainless steel for a solid hold of the measuring head. It has a very long life. An endless screw in the middle acts as a lift to move the arm and the measuring head.

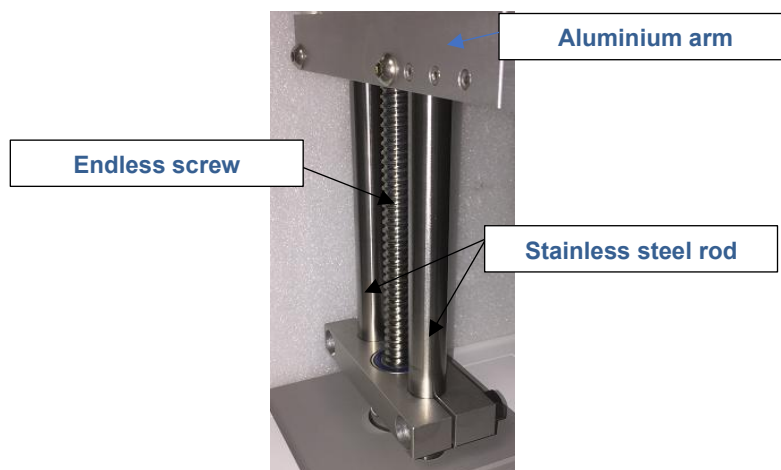

- **Temperature unit CP4000**

This device is present only for models N240250, N240256, N240600, N240800 and N240900 and allows you to regulate the temperature of your sample. It is equipped with an OMRON display/regulator (programmer for certain models).

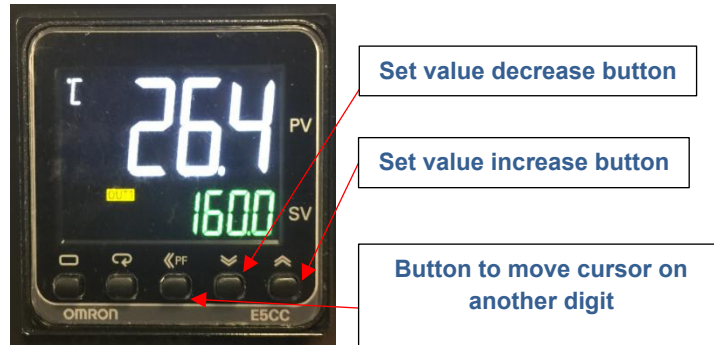

To adjust the temperature on models N240251, N240257, N240601, N240801 and N240901 please see section 2.9.

It is available in Peltier or electric version (see characteristics). The lower plate unscrews clockwise and is interchangeable to adapt to the diameter of the measuring geometry (other dimensions on request).



Models N240256 and N240257 get chamber to insert MB-DIN and MB-SV chamber.

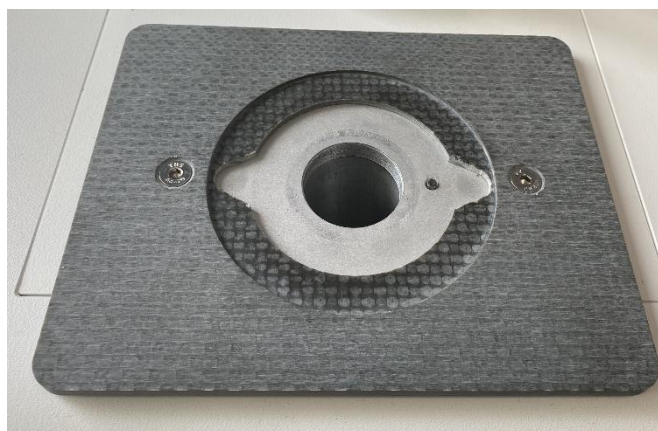

1.3 Connections

According to your order, rear panel of device get these available connections.

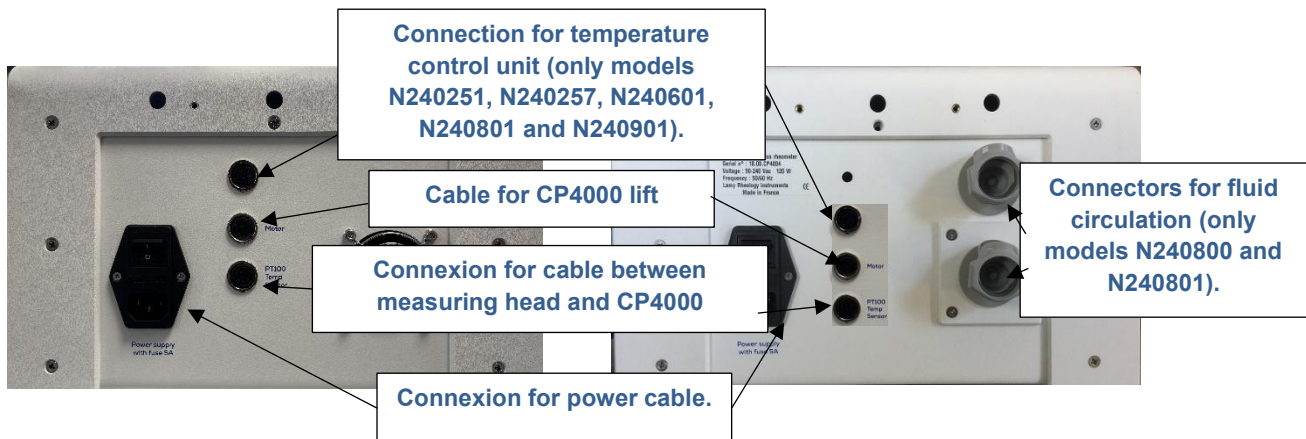
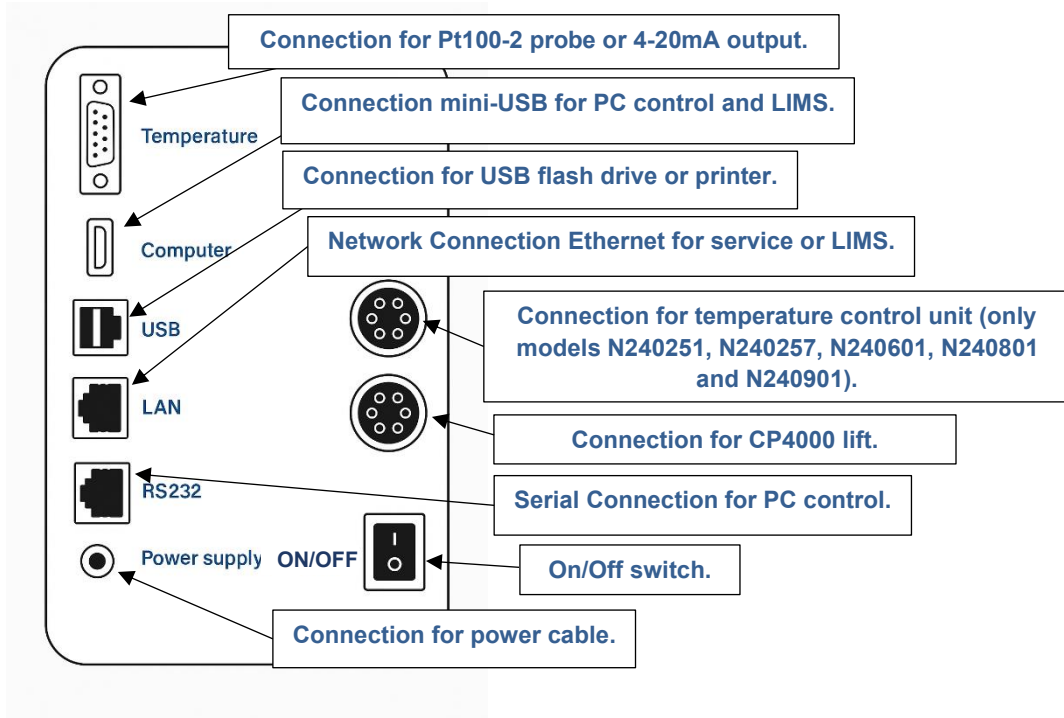

1.4 Specifications

Type of instrument: Rotating springless instrument with 7" Touch screen

Rotation speeds: Unlimited number of speeds between 0.3 and 1500 rpm

Torque range: From 0.05 to 30 mNm.

Accuracy: +/- 1 % of the full scale

Repeatability: +/- 0,2 %

Display: Viscosity – Speed – Torque – Time - Temperature - Choice of viscosity units: cP/Poises or mPa.s / Pa.s

Language: French/English/Russian/Spanish/Turkish/German/Italian/Korean/Portuguese.

Compatible measuring system: MS-CP/MS-PP. **Models N240256 / N240257 :** MS VANE, MS SV and MS DIN.

Supply voltage: 90-240 VAC 50/60 Hz

Connection: USB, RS232 and Ethernet

Options: See brochure

Dimensions and weight: L340 x P610 x H700 mm. Weight: 22 kg.

This is the available models:

Part Number Instrument	Designation Instrument
N240250	RM 200 CP4000 PLUS RHEOMETER AIR-AIR PELTIER (+10 to + 70 °C)
N240251	RM 200 CP4000 PLUS RHEOMETER AIR-AIR PELTIER (+10 to + 70°C) with programmer*
N240256	RM 200 CP4000 PLUS RHEOMETER + CYL*** AIR-AIR PELTIER (+10 to + 70 °C)
N240257	RM 200 CP4000 PLUS RHEOMETER + CYL*** AIR-AIR PELTIER (+10 to + 70°C) with programmer*
N240600	RM 200 CP4000 PLUS RHEOMETER AIR-AIR PELTIER (+0 to +150°C)
N240601	RM 200 CP4000 PLUS RHEOMETER AIR-AIR PELTIER (+0 to +150°C) with programmer*
N240800	RM 200 CP4000 PLUS RHEOMETER LIQUID PELTIER** (-20 to + 100 °C)
N240801	RM 200 CP4000 PLUS RHEOMETER LIQUID PELTIER** (-20 to + 100 °C) with programmer*
N240900	RM 200 CP4000 PLUS H RHEOMETER (Room to +300°C)
N240901	RM 200 CP4000 PLUS H RHEOMETER (Room to +300°C) with programmer*

*) Device able to set temperature ramp with RheoTex software

**) Need water bath with circulation. Not included

***) Can use MS DIN, MS SV and MS VANE. See section 3 for more detail.

1.5 Installation

Install the RM200 CP4000 on a solid bench. Place the level on the plane and adjust the level using the 2 keys provided by playing on the three adjustable feet in height.

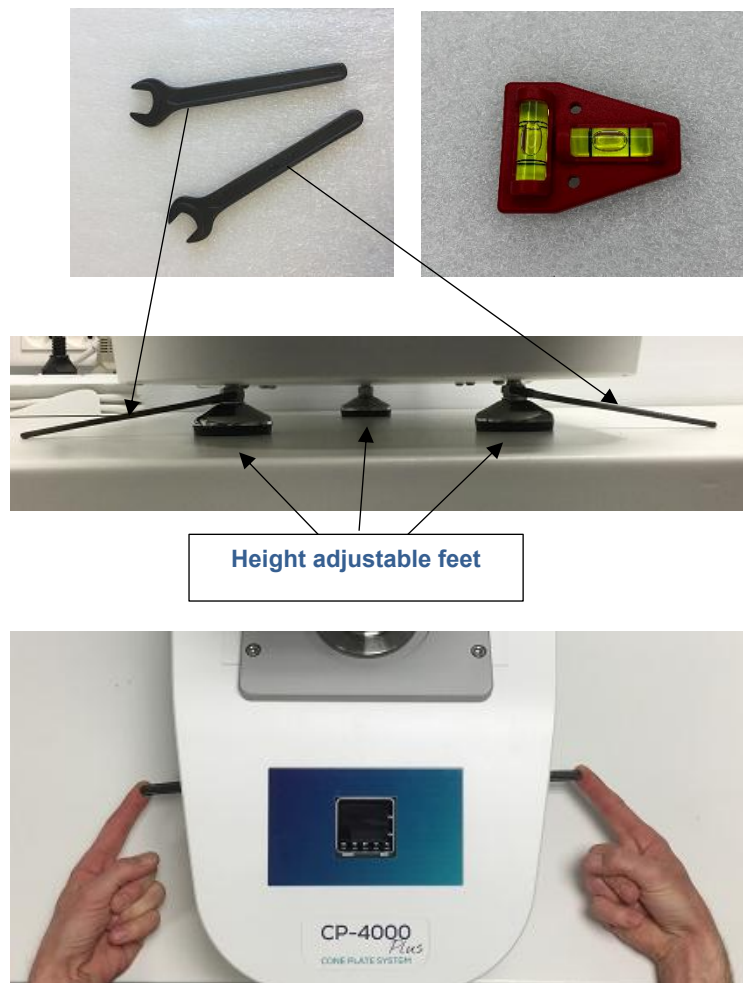

Connect the power cable. Connect the temperature reading cord (blue): SUB-D 15 connector on rear of the RM PLUS to the DIN plug on the back of the CP4000 stand. Connect the black cable for lift control between measuring head and CP4000.

Connect the RM200 PLUS and CP4000 power cable. As well as the cable for the software connection when supplied.

Some models like N240800 and N240801 require liquid circulation. You need to connect the supplied hose to the circulating bath. The direction of circulation does not matter. Please note to always turn on the circulating bath before using the rheometer. Your viscometer will be used with different measuring system. To know how to mount and use it, please see section 3.

2 GETTING STARTED

Once power cable has been plugged on rear panel of device, you can click on button On/ Off from behind your device to switch on (see section 1.3).

2.1 State icons

Once your device is switched on, you will see some icons on Touch Screen.

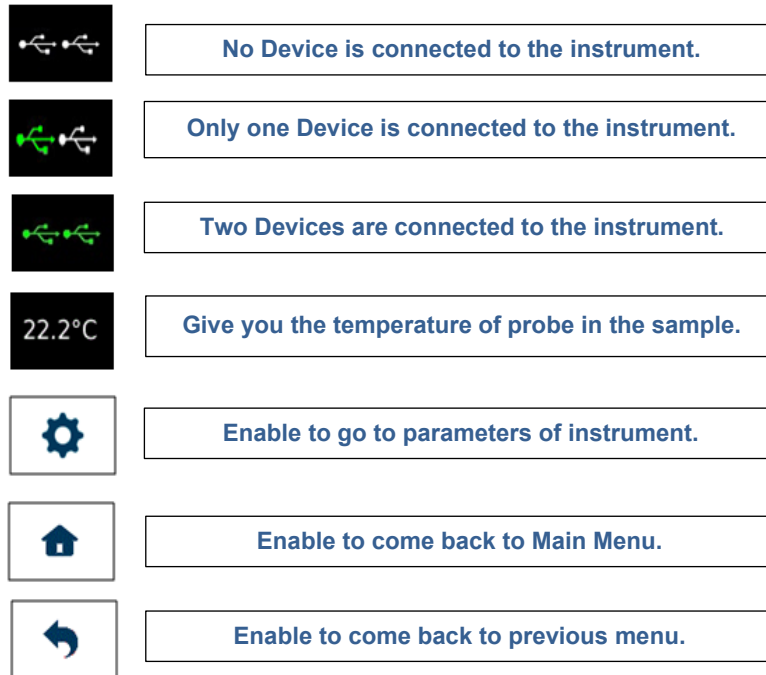

2.2 Main Menu

Main menu enable you to browse between different tabs of your instrument. Acces is always available by clicking.

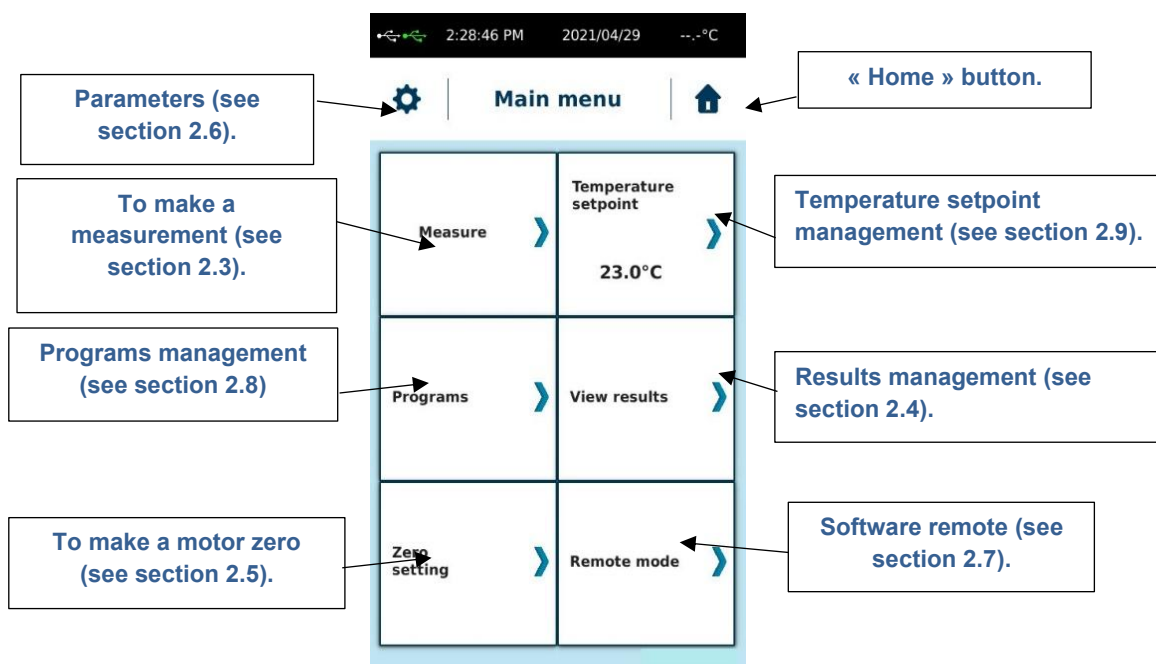

The "Temperature setpoint" button is present only for models N240251, N240257, N240601, N240801 and N240901.

2.3 Measure menu

Measure tab is central part of your instrument. Before to use it, you should install your measuring system and your sample (please see section 3).

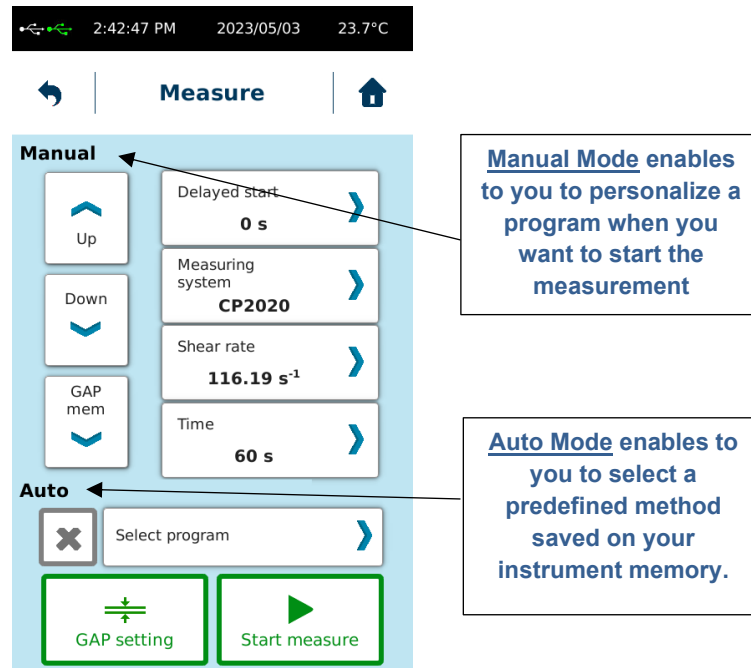

The arrows and lift functions (gap adjustment) are explained in paragraph 3.

2.3.1 Manual measure mode

Manual Mode enables to choose your measurement parameters like "Measuring System", "Speed or shear rate", "Time of measurement" and "Delayed start".

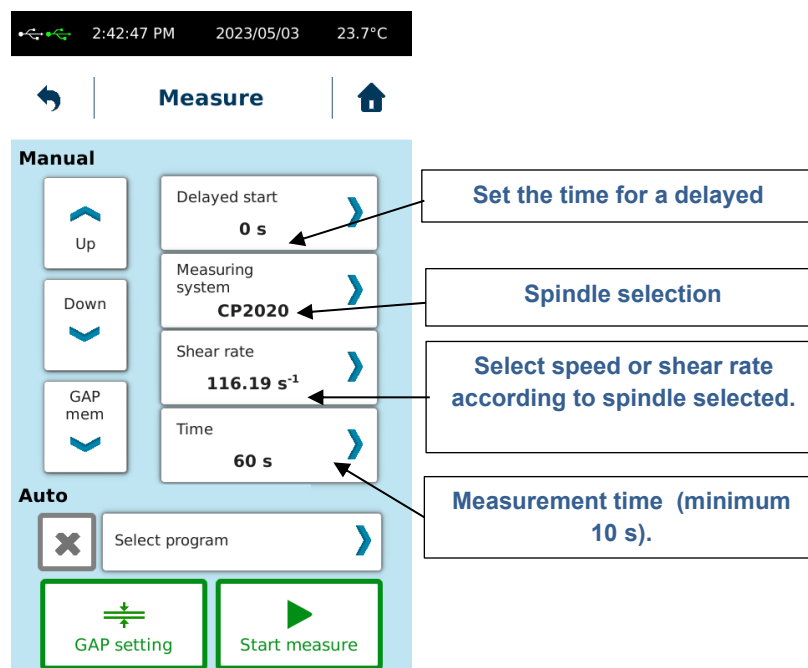

Rq : If « Time » = 0, you could modify « speed » during the measurement. This could help you to define the best conditions to work on your sample.

If your measuring system is not in list, you may have to create it. Please refer to section 2.6.6.

Choice between “Speed” or “Shear rate” is according to your measuring system. For MS VANE, you should have only possibility to set the speed. For all other measuring system, you can use shear rate or speed if you force it to show rpm (see section 2.6.9). If you need to know what is the corresponding speed then you are using shear rate, you have to use constant K_D of your measuring system (information available in section 2.6.6).

$$\text{SPEED} = \text{SHEAR RATE} / K_D$$

With speed unit in rpm, shear rate in s^{-1} and K_D is rpm/s^{-1} .

When your parameters are entered, make sure that the zero adjustment of the motor has been performed before starting your measurement. Depending on the model of instrument you have, the procedure may be different (see section 2.5).

Make sure that the measuring system you are using has been correctly installed (see section 3).

When all these checks have been carried out, you can click on "Start measure" to start your measurement.

If a delayed start has been requested, the instrument displays a countdown then switches to the next view.

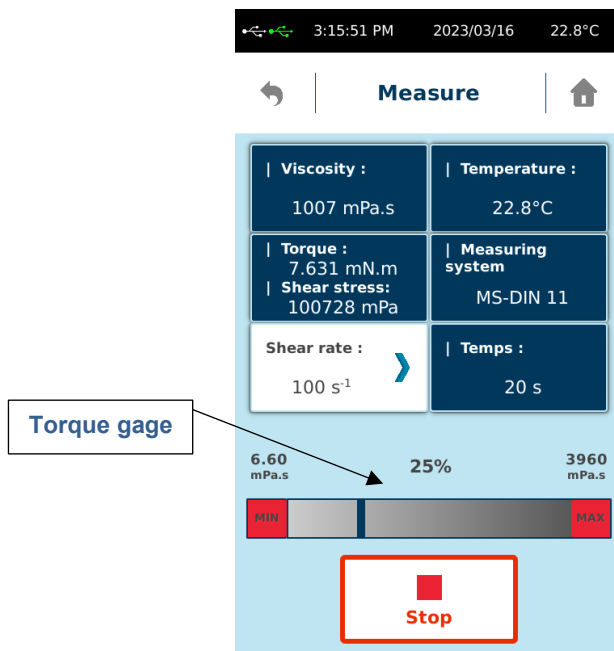

While measurement in manual mode you will see a torque gage (on the bottom side of the display). Boundaries of this gage give you minimum and maximum viscosity you can measure with your selected spindle and set speed/shear rate. You have also value in % corresponding of measured torque vs maximum torque of device. This maximum torque or viewing % can be set on device (see section 2.6.8 and 2.6.9).

You must verify that the measured torque is not too close to the upper or lower limit, because you can get message as “Lower Torque” or “Torque Overload” and measurement will stop automatically. If this is the case, increase speed/shear rate or take a larger measurement system if you are close to the lower limit. Please decrease speed/shear rate or choose a smaller measurement system if the torque reading is close to the upper limit.

You will find several information available on the screen such as torque (mN.m), Shear stress (Pa, can be set on section 2.6.9), temperature (° C), time (s) or viscosity (mPa.s). If the units do not suit you, you can change them in parameters (see section 2.6.5).

Then your measurement is finished, you will get this window below. You will find all data you need and get possibility to save them into internal memory or print it if printer is connected. If you choose “Save”, instrument will ask you to give a name of your measurement. You will have after possibility to read it later (see section 2.4).

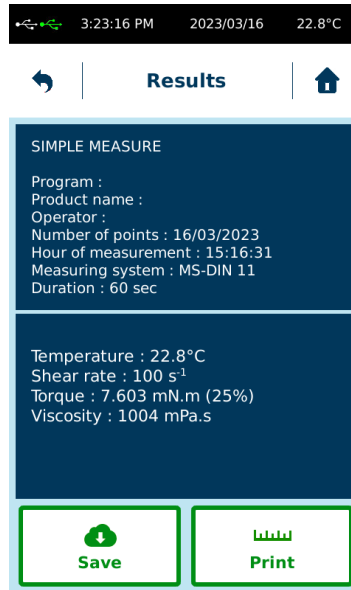

2.3.2 Automatic measure mode

Auto mode allows you to select pre-recorded programs (see section 2.8). Press “Select program” to see the list of saved method.

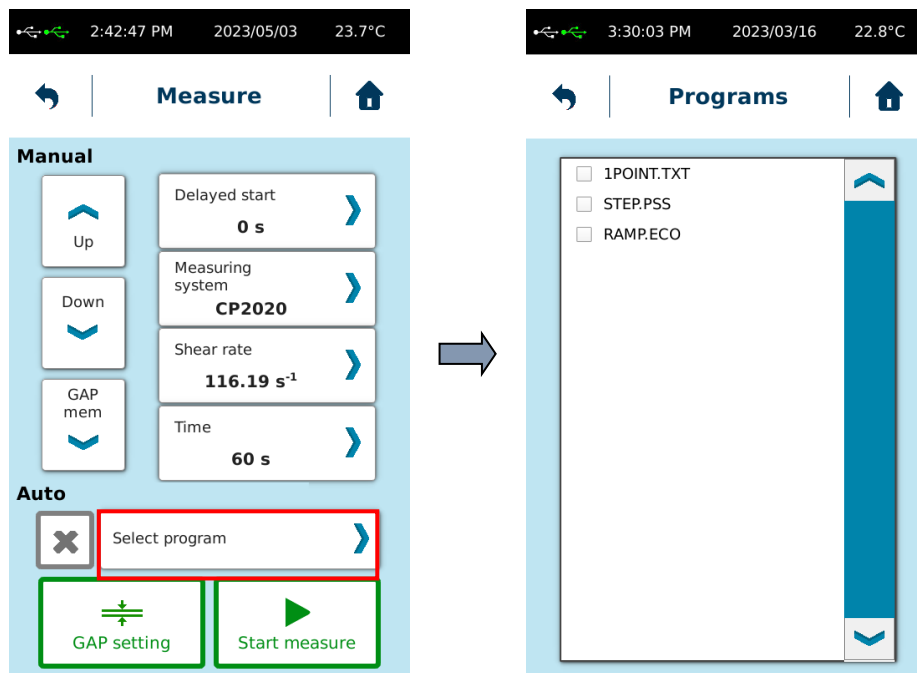

The extension shown next to the program name indicates the type of method according to: “*.TXT” for 1-point method, “*.PSS” for step method and “*.ECO” for ramp method.

Select the program to use. The instrument displays the measurement view with some information from the selected method.

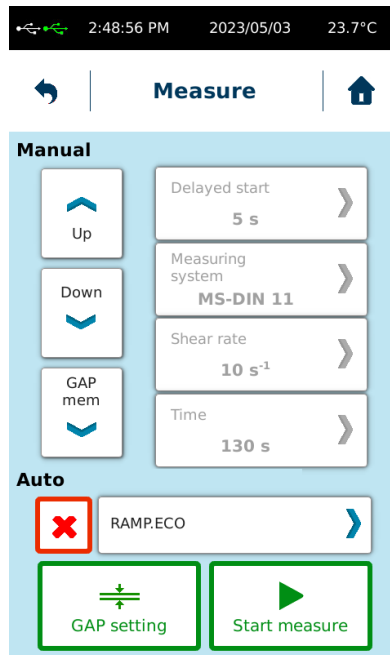

If you made a mistake in choosing the method, you can use the symbol  to allow you a new selection.

When your parameters are entered, make sure that the zero adjustment of the motor has been performed before starting your measurement. Depending on the model of instrument you have, the procedure may be different (see section 2.5).

Make sure that the measuring system you are using has been correctly installed (see section 3).

When all these checks have been carried out, you can click on "Start measure" to start your measurement.

2.3.2.1 1 point method measure mode

The results displayed during the measurement is no different from the manual mode with simple measurement (see paragraph 2.3.1).

At the end of measure, instrument show you this new window with important information according to settings of your method.

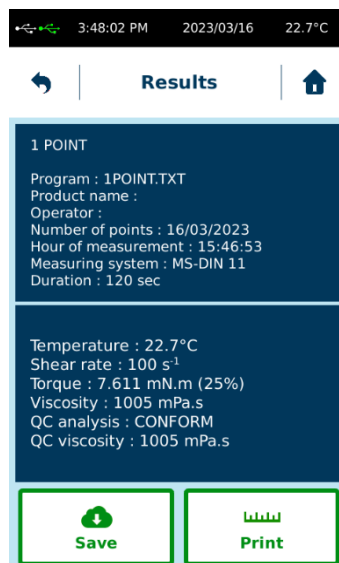

Additionally, to explication on section 2.3.1, you see type of method with name of program on first part of display. On second part of display, you show information about QC analysis if your program had it (see section 2.8.1.1). "QC viscosity" is the measured value used for "QC analysis".

You will find all data you need and get possibility to save them into internal memory or print it if printer is connected. If you choose "Save", instrument will ask you to give a name of your measurement. You will have after possibility to read it later (see section 2.4).

2.3.2.2 Step method measure mode

After starting the measurement using a step method, the instrument asks you for a file name to save in its memory.

If a delayed start has been requested, the instrument displays a countdown then switches to the next view.

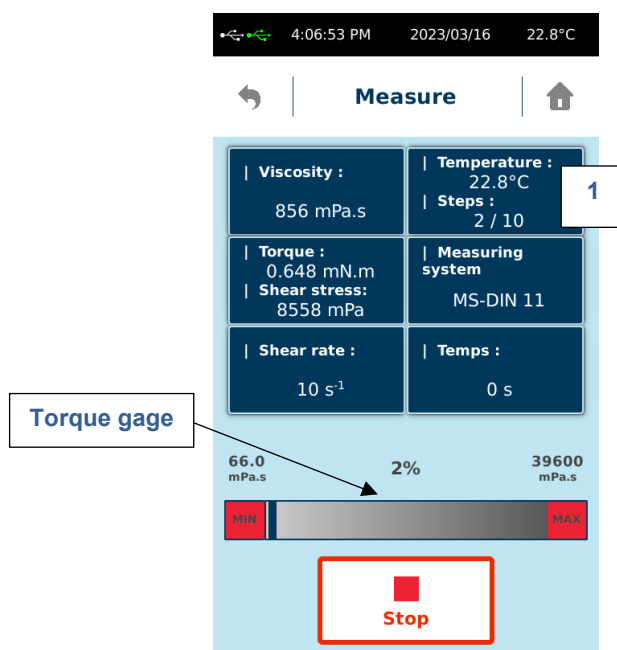

During your measurement, the instrument displays several information. The case marked "1" changes during the measurement. If you have set a setpoint temperature with a start when the setpoint is reached (see section 2.8.1.2), the instrument displays the current temperature and the elapsed waiting time. When the setpoint condition is reached, case "1" switches to the display of the step in progress.

The instrument displays a torque gauge with displayed viscosity limits calculated according to measuring spindle used and the speed or shear rate of each step in progress. The percentage value indicates the ratio between the measured torque and the total torque of the instrument. This maximum torque or percentage display can be set on the device (see section 2.6.8 and 2.6.9).

You must check that the measured torque is not near the upper or lower limit, because you may get the message "Torque too low" or "Torque too high" and the measurement will stop automatically. If so, increase the speed or shear rate of your method's steps or use a larger measuring system if you are near the lower limit. Please decrease the speed or shear rate or choose a smaller measurement system if the torque reading is near the upper limit.

You will find several information available on the screen such as torque (mN.m), stress (Pa) (see section 2.6.9 to display this variable), temperature (°C), time (s) or viscosity (mPa.s). If the units do not suit you, you can change them in the settings (see section 2.6.5).

When your measurement is finished, you will get the window below. You will find all the data you need and will be able to print it if a printer is connected. The instrument displays the results of the rheological analysis and the "QC limits" analysis if your method includes these options (see paragraph 2.8.1.2). Note that the "QC Limits" analysis is performed on the viscosity measured during the last measured step (displayed on the screen after "QC Viscosity"). The data having been automatically saved in memory and you will then be able to read them later (see section 2.4).

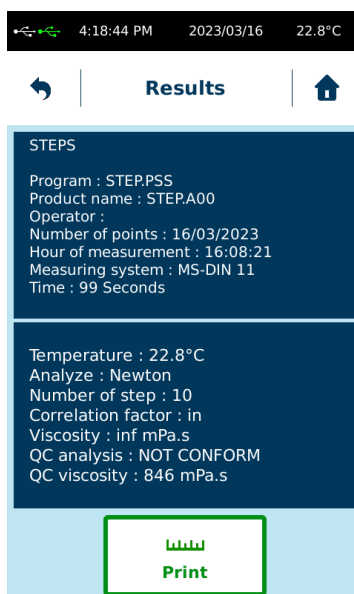

2.3.2.3 Ramp method measure mode

After starting the measurement using a ramp method, the instrument asks you for a file name to save in its memory.

If a delayed start has been requested, the instrument displays a countdown then switches to the next view.

For measurement in Auto mode with “Ramp Method” (see section 2.8.1.3), in addition to the information displayed during the measurement, you will see icons that inform you of the current step of the ramp.

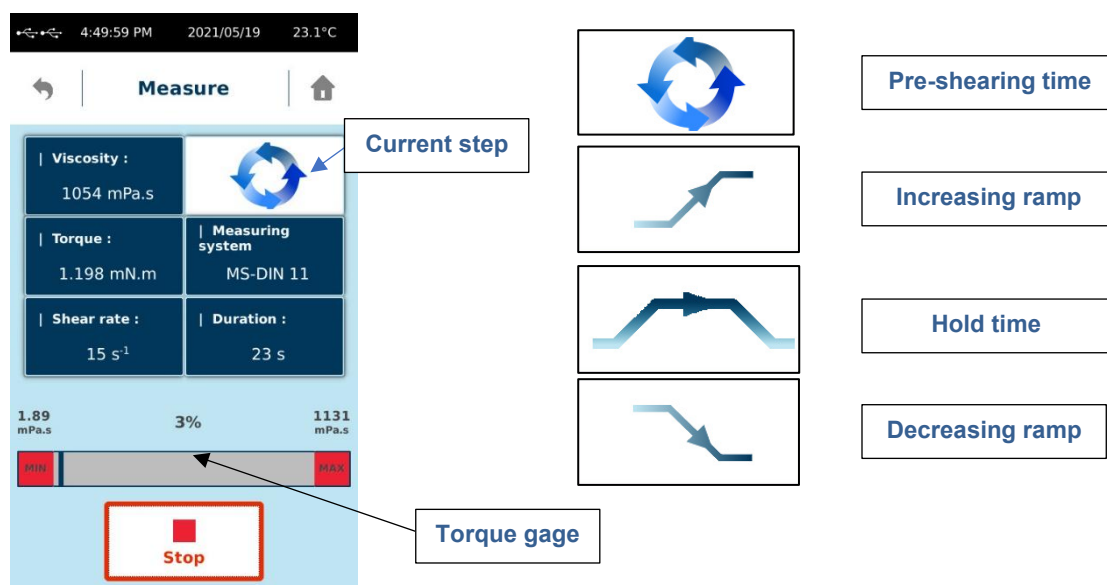

The instrument displays a torque gauge with displayed viscosity limits calculated according to measuring spindle used and the speed or shear rate of each datapoint in progress. The percentage value indicates the ratio between the measured torque and the total torque of the instrument. This maximum torque or percentage display can be set on the device (see section 2.6.8 and 2.6.9).

You must check that the measured torque is not near the upper or lower limit, because you may get the message “Torque too low” or “Torque too high” and the measurement will stop automatically. If so, increase the speed or

shear rate of your method's ramp or use a larger measuring system if you are near the lower limit. Please decrease the speed or shear rate or choose a smaller measurement system if the torque reading is near the upper limit.

You will find several information available on the screen such as torque (mN.m), shear stress (Pa) (see section 2.6.9 to display this variable), temperature (°C), time (s) or viscosity (mPa.s). If the units do not suit you, you can change them in the settings (see section 2.6.5).

When your measurement is finished, you will get the window below. You will find all the data you need and will be able to print it if a printer is connected. The instrument displays the results of the rheological analysis if your method includes this option (see paragraph 2.8.1.3). The data having been automatically saved in memory and you will then be able to read them later (see section 2.4).

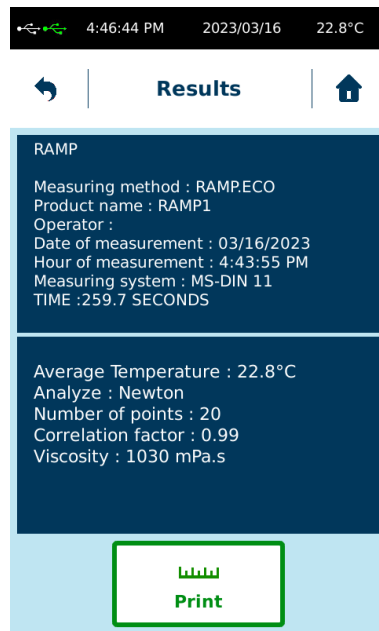

2.4 View results menu

This menu allow you to read, export or delete data from internal memory. Press on « View results » tab in Main menu.

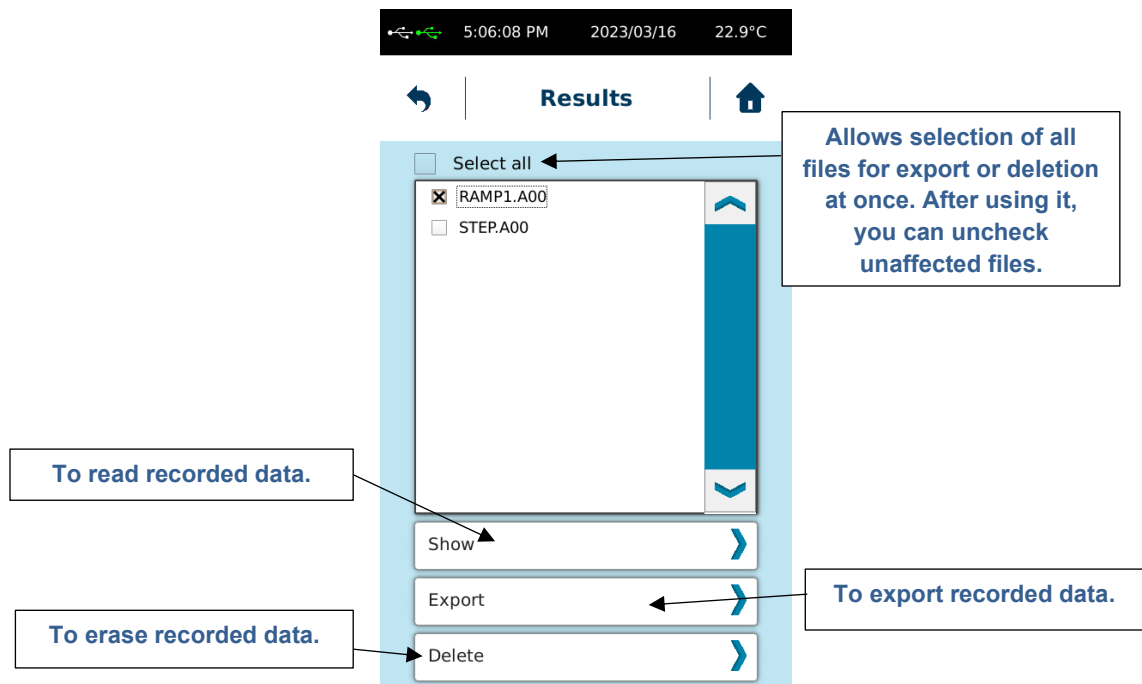

2.4.1 Show results

By clicking on this tab, you will be able to view the information concerning the selected measure. The data display format is the same as the one you get at the end of the measurement (see paragraph 2.3.2). You also have the possibility of printing or exporting depending on whether a printer or a USB key is connected to the instrument.

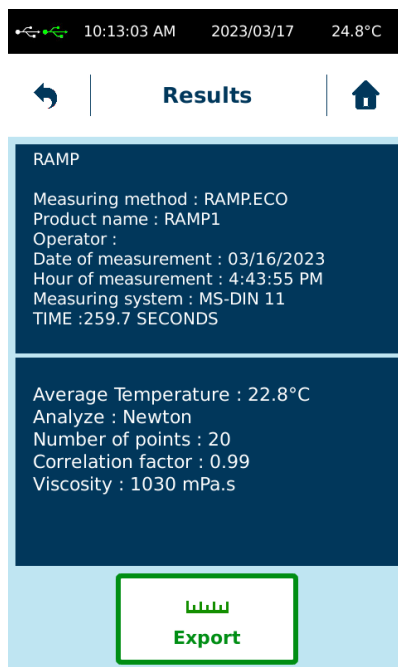

2.4.2 Export results

By clicking on "Export" you can transfer the measurements recorded to a USB key if it is connected to the back (see section 1.3). The "Select all" function allows you to export all the measurements at once.

The format of the data generated and saved by the instrument is ASCII (*.txt). Once your data has been copied to the USB drive, you can open the files using the EXCEL spreadsheet. To do this, simply copy the data from the USB key to your computer. Then open Excel, choose "File", "Open", taking care to select "All files *. *".

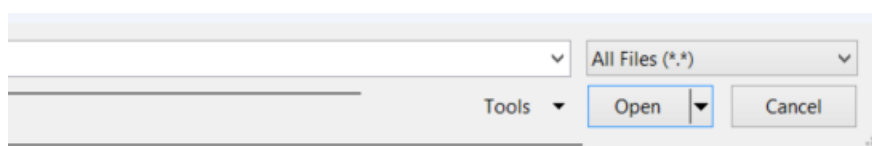

Find your file and click "Open". Excel will offer you to convert your data by displaying three successive windows.

Select "Unicode UTF8" and "My data has Header" (last selection available according Office version) and click "Next".

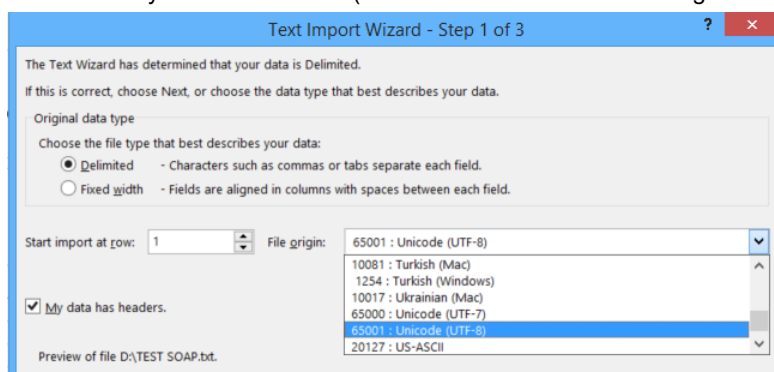

On second step, it will be necessary to choose the option "Tab" and "Semicolon" for separation of the columns. For "Text qualifier", you should set "none".

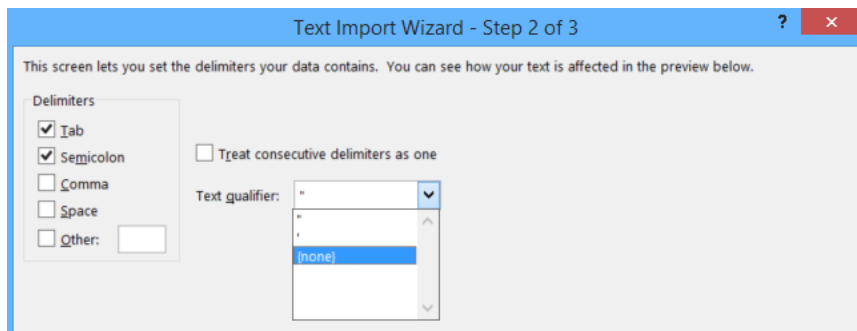

On last step, please choose "General" and click "Finish".

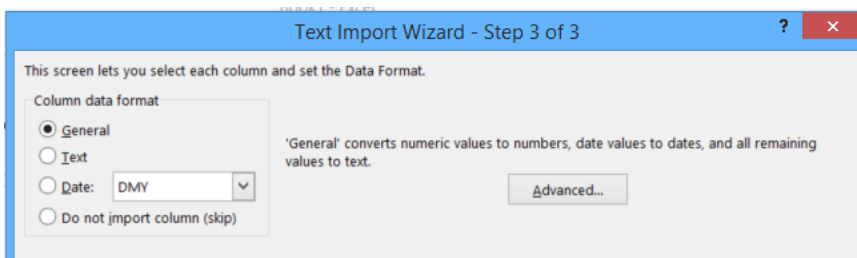

You can then see your measurement results with the possibility to save a new file in Excel format.

2.4.3 Delete results

By clicking on this tab, you can delete all the measurements recorded on your instrument. The "Select all" function allows you to delete all the measurements at once.

When you click "Delete", the recorded data will be completely deleted from the internal memory after further confirmation from you.

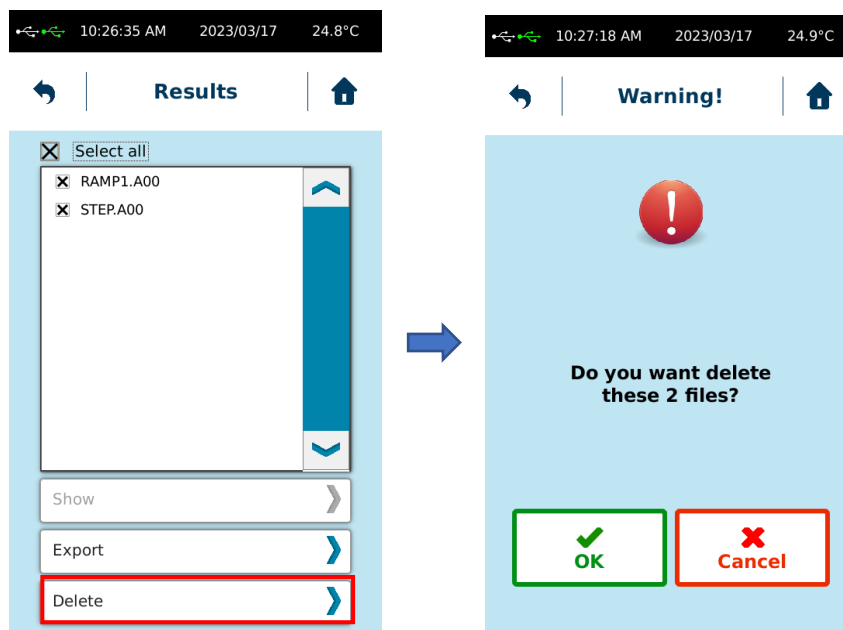

2.5 Zero setting

The zero setting allows you to calibrate your instrument to take account of the engine's empty friction.

Zero setting allows you to calibrate your instrument and take care of motor internal friction.

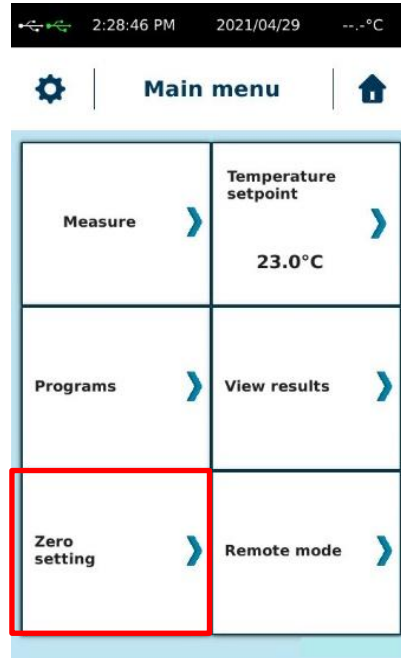

For standard instruments, this operation must be done without mobile. The rotational speed for zero adjustment is available on the same window. The rotation speed for zero adjustment can be changed to suit your needs, giving you much more accurate measurements at specific speeds near to your measurement parameters.

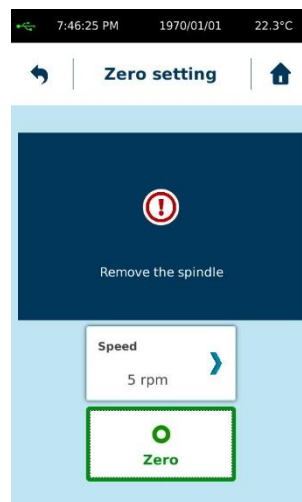

Then zero is finish you can click on OK and internal motor friction will be automatically saved inside memory of instrument. If problem occur during zero setting, please try again. If problem still present, please contact your local distributor or society LAMY RHEOLOGY.

2.6 Parameters menu

This parameters menu allows you to change settings of your device. It is reachable by clicking on icon “” in upper left corner of touch screen.

This icon is only available then you are in “Main menu”.

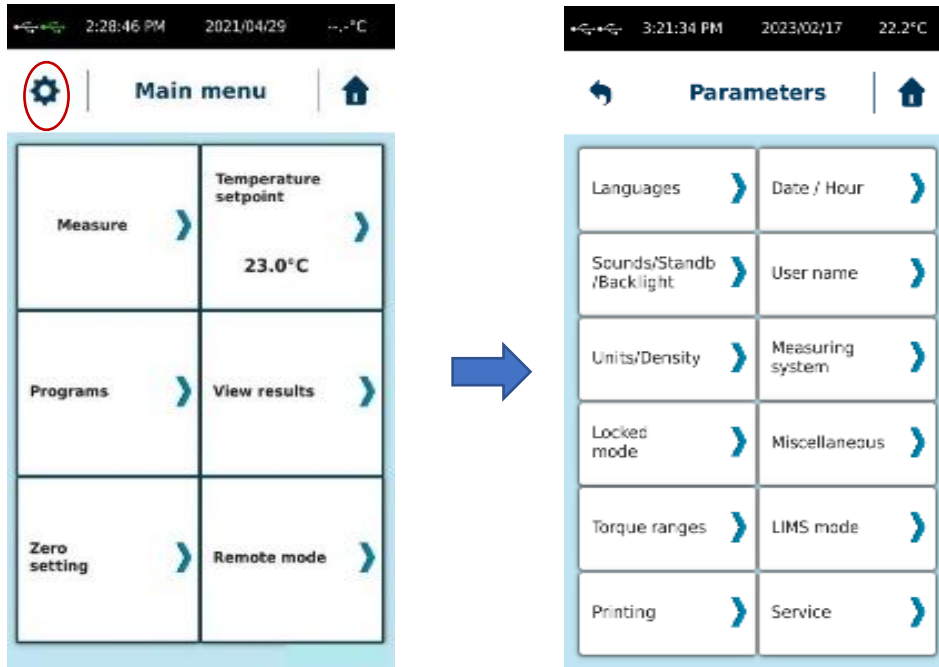

2.6.1 Languages

Enable you to select language of your instruments. You have choice between French, English, Russian, Turkish, Deutsche, Italian and Spanish. Then you have selected your desired language, you have to click on “Ok” and device will reboot automatically to show new language. In this menu you will be able to see Firmware version of your device.

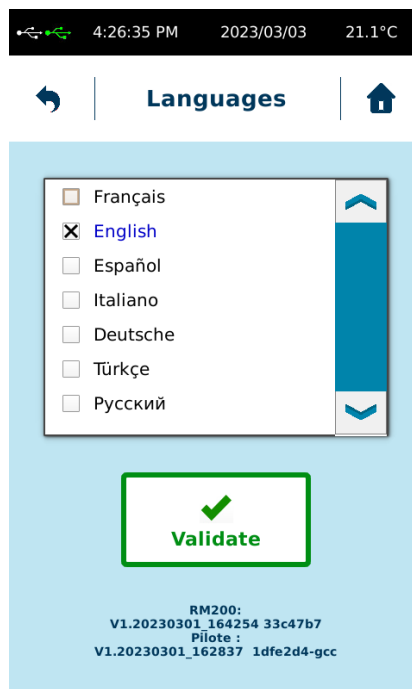

2.6.2 Date / Hour

Enable you to select language of your instruments. You have choice between French, English, Russian, Turkish, Deutsche, Italian, Korean, Portuguese and Spanish. Then you have selected your desired language, you have to click on “Ok” and device will reboot automatically to show new language. In this menu you will be able to see Firmware version of your device.

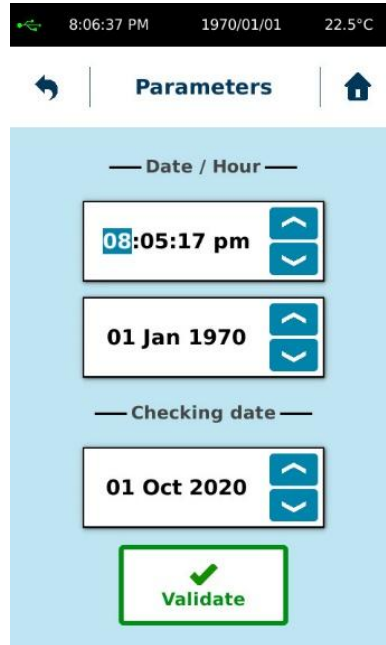

2.6.3 Sounds/Standby/Lighting

Allow you to modify sounds, lighting and activate or not the Standby mode of your instrument.

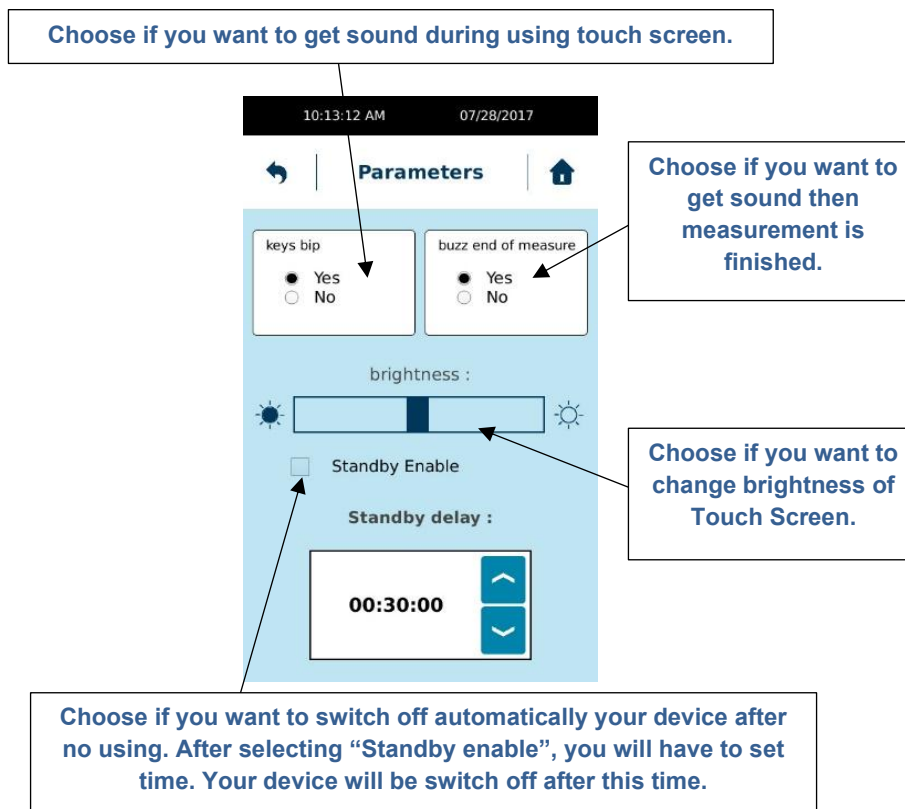

2.6.4 User Name

Operator mode will allow you to create different operators for your instrument. The use of the operators makes it possible to identify the person making the measurement (to save name on saved file and see later who made this measurement) or lock some function on device for simple user.

Operator management must always begin with the creation of the first account, which will become the administrator and thus create or delete another operator account. Click on "Create new user with PIN code". After specifying the name and password, the administrator will be named in red in the list.



You can now create another operator. The account of an operator may or may not be associated with a password (here called PIN code).

To delete an account, the administrator account must be used. Select the account you want to delete from the list and click on "Delete user name".

To use the operator accounts you must activate the mode by click "Enable User mode". Device will ask you to select user name you want to use. By returning to the Main Menu, you will see the name of the operator in use. By clicking on the arrow below the name of the operator, you can switch off the instrument or change operator. Click on "Logout" and device will ask you operator account you want to use

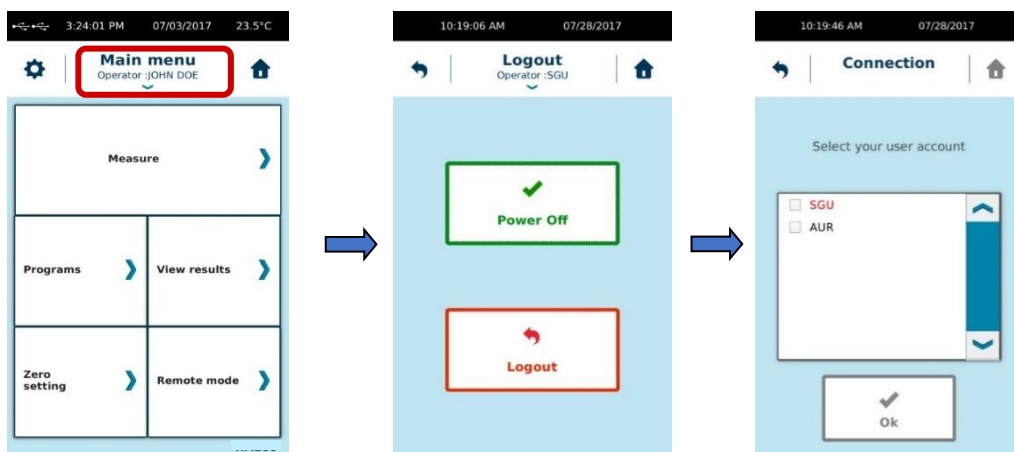

If the instrument is switched OFF and ON while operator mode is activated, device will ask you to select the operator you want use.

When User mode is enabled, some functions will be not editable for simple user as picture below shows it.

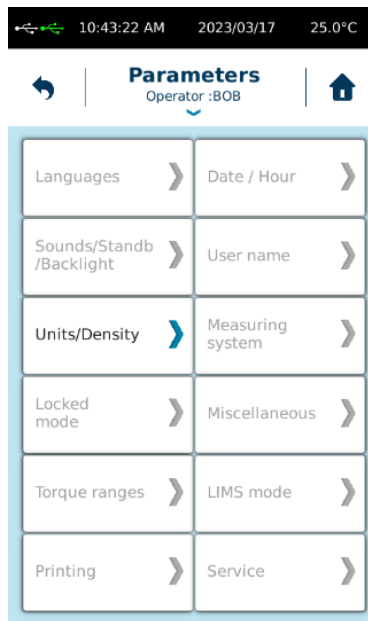

2.6.5 Units/Density

Enable you to change unit of viscosity values and to enter density value of your product to measure in order to calculate its kinematic viscosity.

If you set a density value, you will get all the time kinematic viscosity in cStoke. Please remove density information if you want to get back Pa.s or Poise for unit of viscosity.

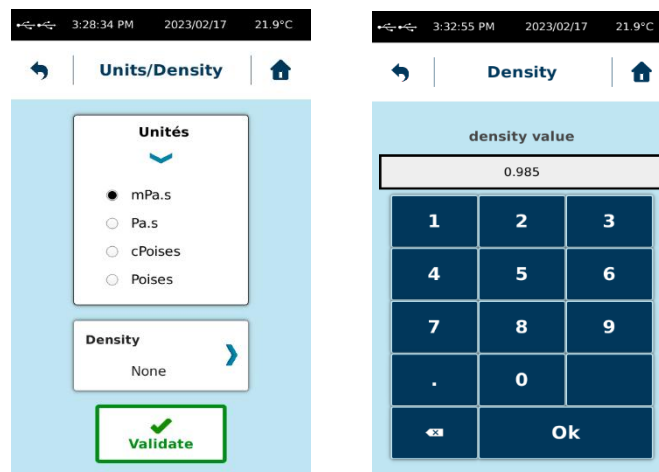

2.6.6 Measuring System

Allows you to add, copy or delete a Measurement System. All measurement systems stored by default in memory are not removable. Only those you have created yourself can be removed. To delete a measuring system, select it from the list and choose "Delete Measuring System". If this function remains greyed out when you have selected a system, it is part of the default mobile stored in the instrument's memory.

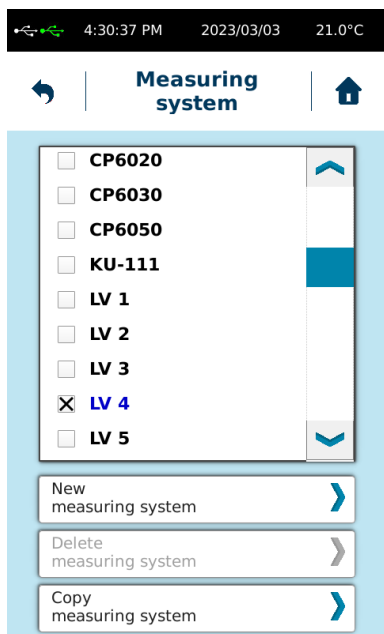

To add a new measuring system, you can use "New measuring system" or "Copy measuring system" functions. Device will ask you name and constants for this measuring system. In case of copy, device will propose you to keep constant from previous measuring system but you can modify them.

You are not allowed to change the constant of an existing measuring system. If you want to use a new constant for an existing measuring system, you have to copy and modify it. Note that the KD constant is used to convert rotational speed to shear rate and K τ to convert torque to shear stress. Shear rate and shear stress are used to calculate the viscosity value. If you use a different constant value, you will get a different viscosity result.

Here is the list of constants used for measuring systems compatible with the instrument.

MS CP

SYSTEM	K τ / 1 mNm in Pa	Kd / 1 RPM in S-1	Ri / Ra
CP 2005	477.5	12	1
CP 2015	477.5	3.8	1
CP 2020	477.5	3	1
CP 2045	477.5	13.3	1
CP 2405	276.3	12	1
CP 2420	276.3	3	1
CP 2445	276.3	13.3	1
CP 2520	244.5	3	1
CP 3020	141.5	3	1
CP 3520	89.1	3	1
CP 4005	59.7	12	1
CP 4015	59.7	3.8	1
CP 4020	59.7	3	1
CP 4040	59.7	1.5	1
CP 4221	51.6	3.8	1
CP 4530	41.9	2	1
CP 5005	30.6	12	1
CP 5010	30.6	6	1
CP 5020	30.6	3	1
CP 6005	17.7	12	1
CP 6010	17.7	6	1
CP 6020	17.7	3	1
PP 25 0.5	326	2.618	1
PP 25 (1mm)	326	1.309	1
PP 25 (2mm)	326	0.654	1
PP 40 (0.5mm)	79.5	4.188	1
PP 40 (1mm)	79.5	2.094	1
PP 40 (2mm)	79.5	1.047	1

Here is the list of compatible mobiles and their respective constants for models N240256 and N240257. MS-VANE spindles are used with MB-DIN cup (see section 3).

MS VANE

SYSTEME	Ktau / 1 mNm in Pa	Kd / 1 RPM in S-1	Ri / Ra
V72	157	1	0.5
V72/2	270	1	0.5
V72/4	400	1	0.5
V72/6P	150	1	0.5
V-73	785	1	0.5
V-74	7850	1	0.5
V-75	2965	1	0.5
VT105	2180	1	0.5
VT2010	410	1	0.5
VT2020	59	1	0.5
VT3015	80	1	0.5
VT4020	34	1	0.5
VT5025	17	1	0.5

MS DIN

SYSTEME	Ktau / 1 mNm in Pa	Kd / 1 RPM in S-1	Ri / Ra
MS-DIN 11	13.2	1.291	0.92
MS-DIN 12	19.4	0.354	0.73
MS-DIN 13	64.4	0.152	0.43
MS-DIN 22	25.8	1.291	0.92
MS-DIN 23	77.9	0.19	0.54
MS-DIN 33	130.1	1.291	0.92
MS-DIN 19	12.56	3.223	0.97

MS SV and MS ULV

SYSTEME	Ktau / 1 mNm in Pa	Kd / 1 RPM in S-1	Ri / Ra
SV414	877	0.4	0.69
SV415	371	0.48	0.75
SV416	572	0.29	0.53
SV418	59.7	1.32	0.92
SV421	65.9	0.93	0.88
SV425	1918	0.22	0.25
SV427	126.8	0.34	0.62
SV428	205.2	0.28	0.49
SV429	367	0.25	0.40
SV431	166.5	0.338	0.62
SV434	271	0.28	0.49
SVC	68	0.43	0.71

2.6.7 Locked Mode

This option allows you to block measuring parameters. It should be set by an administrator or responsible of the device.

This function is not comparable to the "User name" menu (please see section 2.6.4). It should be use if you want to protect measurement settings on your device. All settings will be not lock by this function. You will see below which settings are concerned.

This function will block also parameters for measure. In this way, if you want to use all the time same parameters for measurement, you should enable this locked mode to be sure that nobody will change settings for measurement.

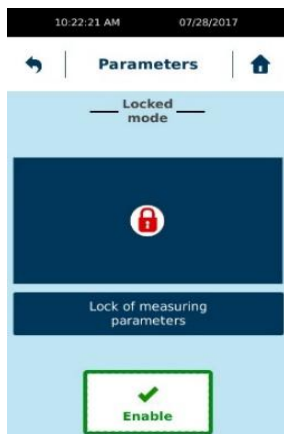

When you click "Enable", the instrument will ask you to save a 4-digit code that will be required to disable this protected mode. Each activation is independent and can be done with a different code. The protected mode is indicated by the presence of a padlock-like icon. **BUT TO DISABLE THIS LOCKED MODE, YOU SHOULD USE 4-digit CODE USED TO ENABLE IT.**

Once protected mode is activated, you will see this icone on instrument's screen (see picture below). Protected mode protect programs, measuring parameters and some menu as shown on pictures below.



To disable "Locked mode", you must return to service and "Locked mode" and click on "Disable" by entering the 4-digit code.

2.6.8 Torque range

Allows you to adjust the torque range of the device when you want to compare the torque displayed in % with a viscometer equipped with spring technology. If comparison with another spring instrument is not necessary, we advise you to select "None". This setting simply changes the range of torque usable during measurement and the viscosity limits.

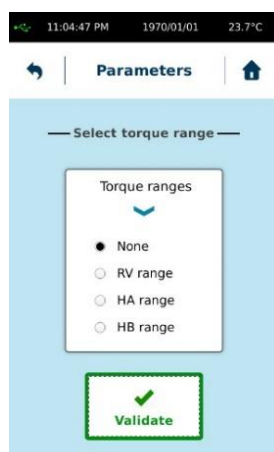

Here are the torque ranges corresponding to the different spring devices:

- RV Range : From 0.07187 to 0.7187 mNm.
- HA Range : From 0.1437 to 1.4374 mNm.
- HB Range : From 0.5749 to 5.7496 mNm.
- None means no limits. So it will be complete range (see section 1.4).

2.6.9 Miscellaneous

This menu allows you to select the temperature sensor used by the instrument. The instrument allows the use of an external probe (Pt100-2) which must be connected to the back of the instrument (see section 1.3). This setting is not available by default on instrument if this device is delivered without external temperature probe. If you buy it later and want to activate this function, please contact your local agent or LAMY RHEOLOGY.

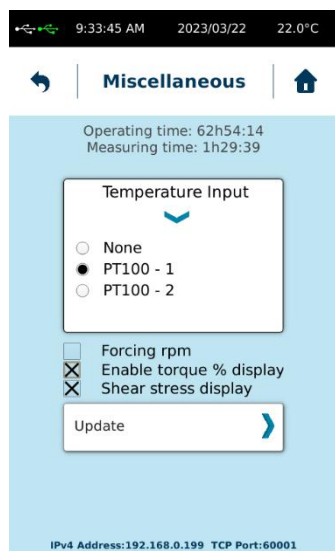

“Update” function is used when updating the machine software is necessary. Do not go in this menu without being invited by the company LAMY RHEOLOGY. The update is done via a USB key connected to the “USB” port. You can then click on “Update” to update your instrument. At the end, your device will turn off and you will have to turn it on again.

“Operating time” and “Measuring time” settings indicate time while device has been switched ON and time while it was used for measurement.

“Forcing rpm” allow you to force device setting only speed in rpm instead shear rate (s-1) when you are using measuring system compliant with DIN 53019 norm (as MS DIN, MS ULV, MS SV).

“Enable torque % display” allow device to show torque in % above torque gage while measurement.

“Shear stress display” function will provide you shear stress value while measuring.

On bottom part of this view, you see information about network identification of this instrument. It helps you to identify instrument when you want to use LIMS function (see section 2.6.10). These parameters can be changed in menu Service (check with your local contact or Lamy Rheology to provide you access).

2.6.10 LIMS mode

This menu allows you to select the data format for the LIMS function. To activate this function, a data format must be selected and a “measurement interval” must be entered. Then the instrument will send data at regular intervals to a client (Server). The destination of the data will be configured via the LIMS software used. The connection used will be Ethernet (LAN) on the rear panel of the instrument. The IP address of the instrument for the LAN connection is visible in the “Miscellaneous” menu (see section 2.6.9). The IP address of the instrument can be changed in the service menu. To do this, please contact LAMY RHEOLOGY or your local contact to provide you with an access password.

The “Measurement interval” function allows you to set the time interval used by the device to send data.

When a data format is selected, it is no longer possible to use the other connections (USB/RS232) for using the RheoTex software.

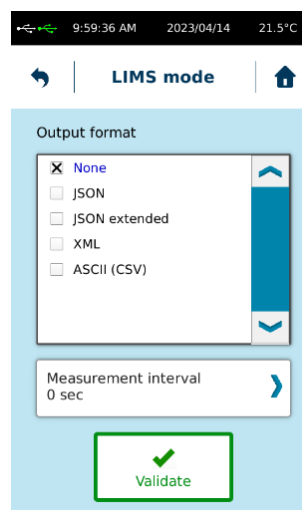

2.6.11 Printing

This menu allows you to connect a printer, print a test page, and choose the print interval time you want during measurement.

The instrument can be connected to all printers with a PCL5 print protocol. This includes many A4 printers. The connection is made to the "USB host" port on the back of the instrument.

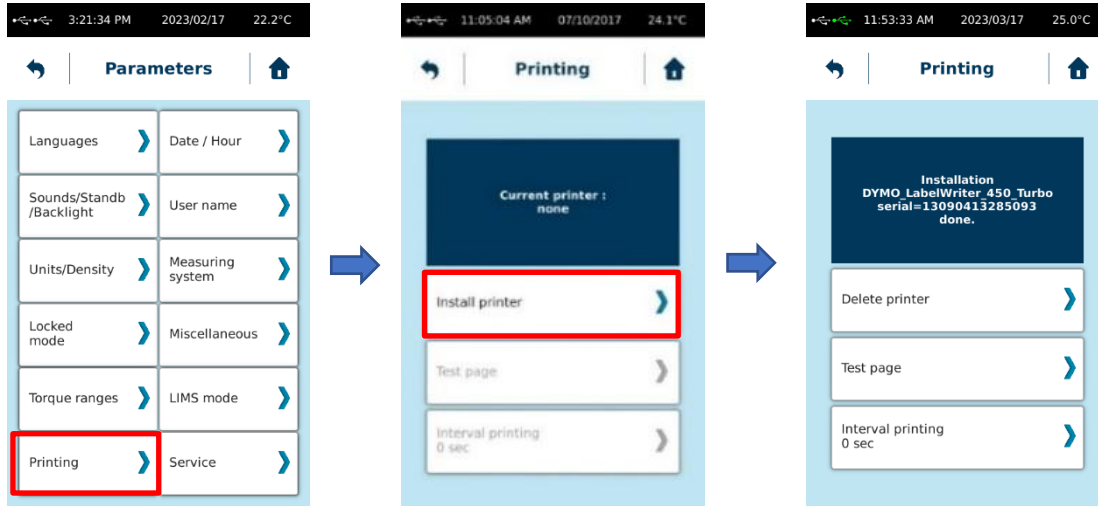

Once the printer is connected, simply click on "Install Printer".

You can also print page for test or set time interval for automatic printing. Then you print data at the end of measure or a saved file, you will have only information shown on device screen as final result. If you want to have more data printed, you have to select "Interval printing" time to get data printed between start and end of your measurement.

2.6.12 Service

Reserved to LAMY RHEOLOGY or local partner engineers.

2.7 Remote mode menu

Remote mode allows you to control your instrument with RheoTex software. If all the connection choices are greyed out and the Ethernet port selected by default, LIMS mode has been activated (see paragraph 2.6.10).

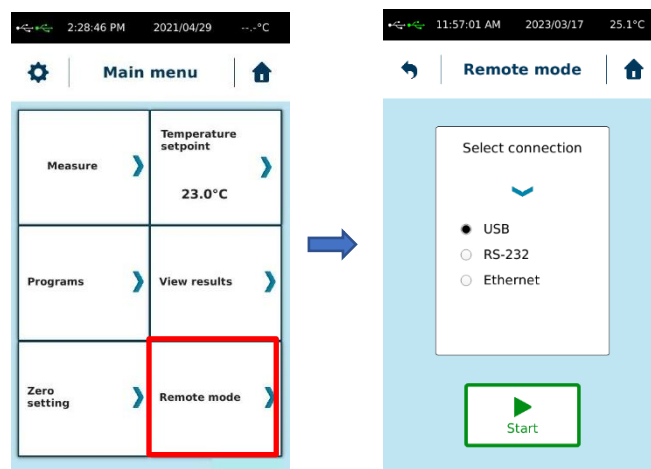

Once the device is connected to the PC, you must select the type of port (USB - RS232 for) and click on "Start" to launch the communication. As long as communication is not established, a "Waiting Connection ..." message

appears on the screen. Then launch the software and check that the screen switches to the display below. If this is not the case, check the connections and make sure that the COM port number set in the default settings of the RheoTex software is correct and identical to that recognized by WINDOWS in "Control Panel", then "System and "Device Management" (see the operating instructions for the RheoTex software).

2.8 Programs menu

In the programs tab you will be able to configure, modify or delete your measurement methods. The saved programs can be found in the "Auto" tab of the "Measure" menu (see section 2.3.2).

When you select the "Programs" function, you get a new window where you can see your recorded methods and functions as "Create program", "Edit Program" or "Delete a program". The "Select all" function can only be used for the deletion of methods.

The extension after the program name indicated the type of method according to: " *.TXT" for 1 point method, "*.PSS" for step method and " *.ECO" for ramp method.

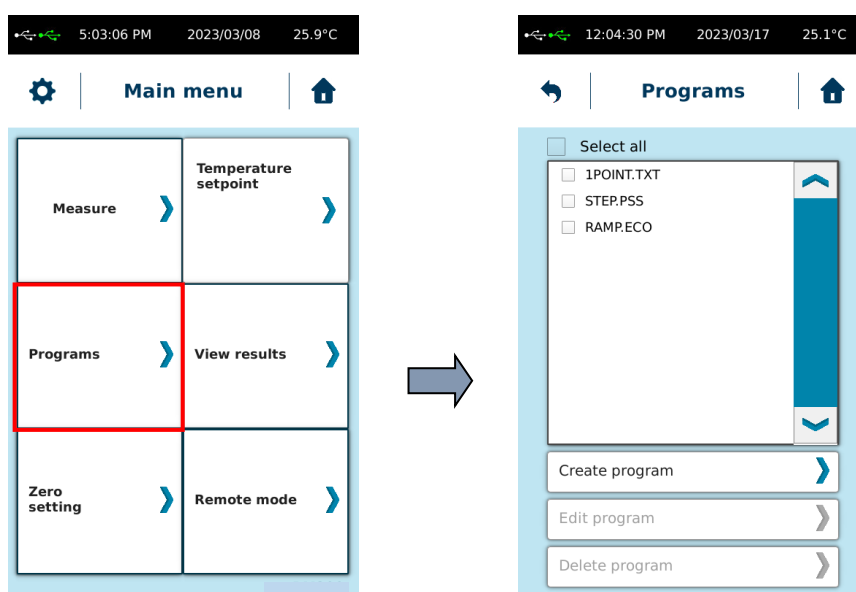

2.8.1 Create new program

By selecting "Create program", the instrument displays the following view.

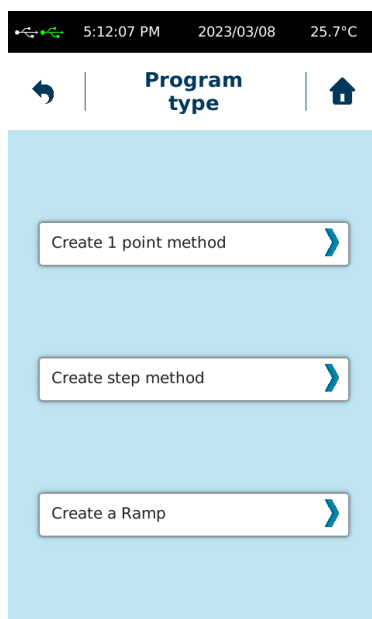

The “1 point method” makes it possible to measure your product viscosity at constant rotation speed or constant shear rate during a defined time. The instrument will display measured viscosity at the end of this measurement time.

The “Step method” allows you to fix measurement intervals at different rotation speed or shear rate in order to obtain viscosity values under different shear conditions. It also makes it possible to obtain a flow curve by fixing interval by interval the shear rate and time.

The ramp method makes it possible to vary the rotation speed or the shear rate by fixing the initial and final value. The ramp will be managed by the instrument with the same time for each measurement point. This method provides a flow curve.

2.8.1.1 1 point method

When you choose 1 point method, the instrument displays the following view.

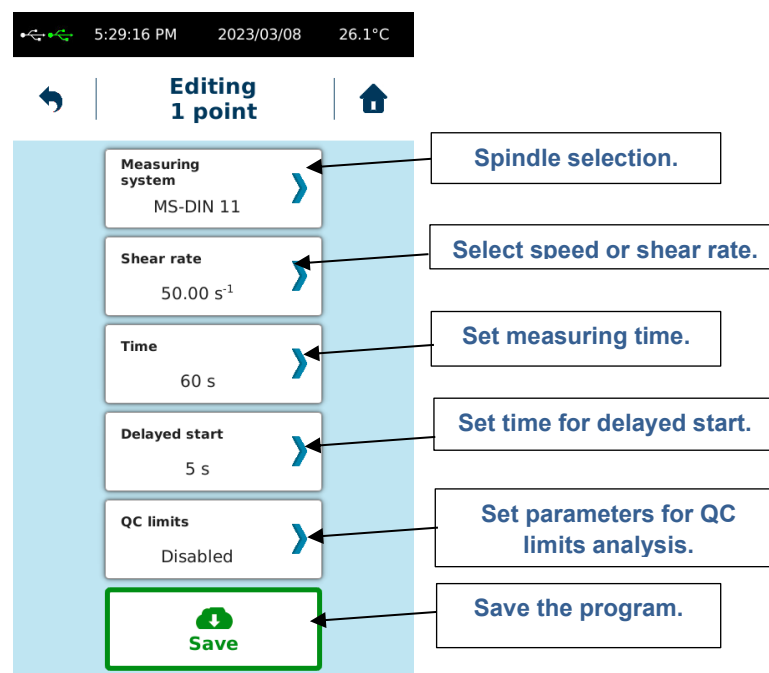

When creating a new method, the next buttons is activated after your validations progresses. According to the selected mobile, the instrument will offer you to fix the shear rate (s⁻¹) instead speed (rpm) as that is the case for MS DIN or MS SV measuring systems. To force rotation speed in rpm, please read section 2.6.9 of this user manual.

The "Delayed start" function allows you to set a waiting time before the measurement. This time will be deducted as soon as you launch the measurement (see section 2.3).

The “QC limits” function makes it possible to verify that the measured viscosity value is between two limits that you have previously set. When choosing this function, the instrument displays the following view.

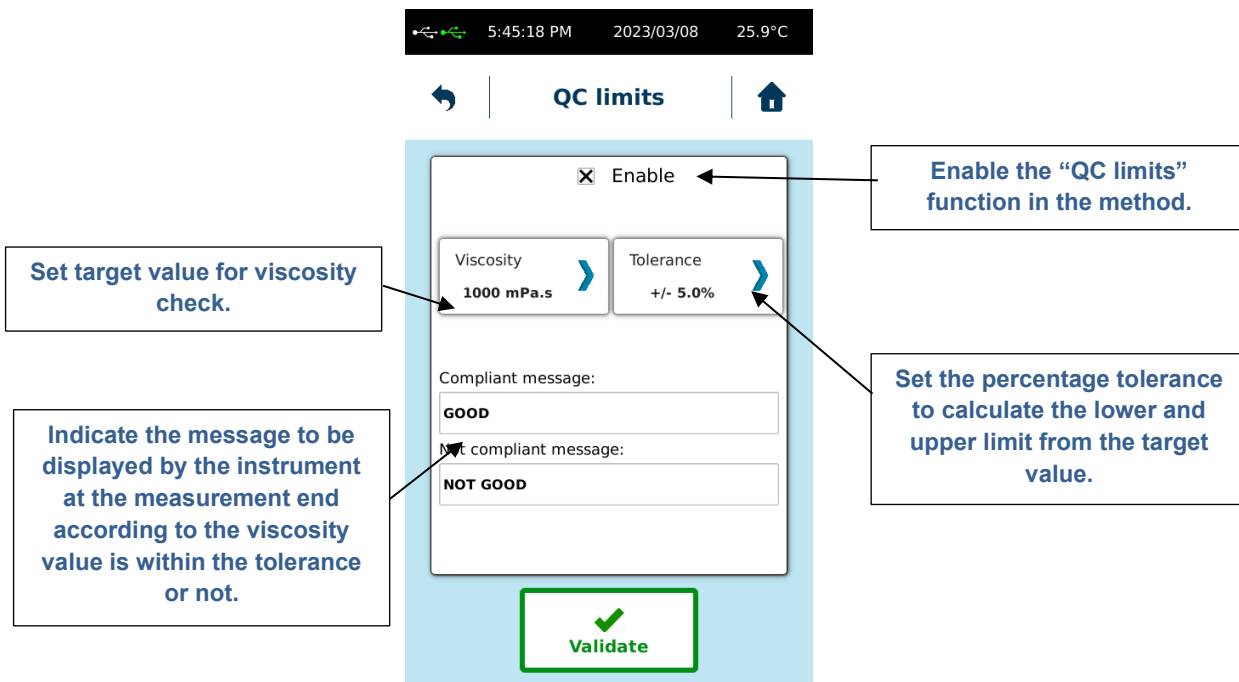

Do not forget to activate the "QC limits" function before validating to exit this window, otherwise the information will not be saved. At the measurement end according to the viscosity value is within the tolerance or not, the instrument will display the message that you have indicated in the "Compliant message" or "Not compliant message" fields.

Once you have finished setting up your method, you can save it by choosing "Save".

2.8.1.2 Step method

When you select step method, you will get the following view.

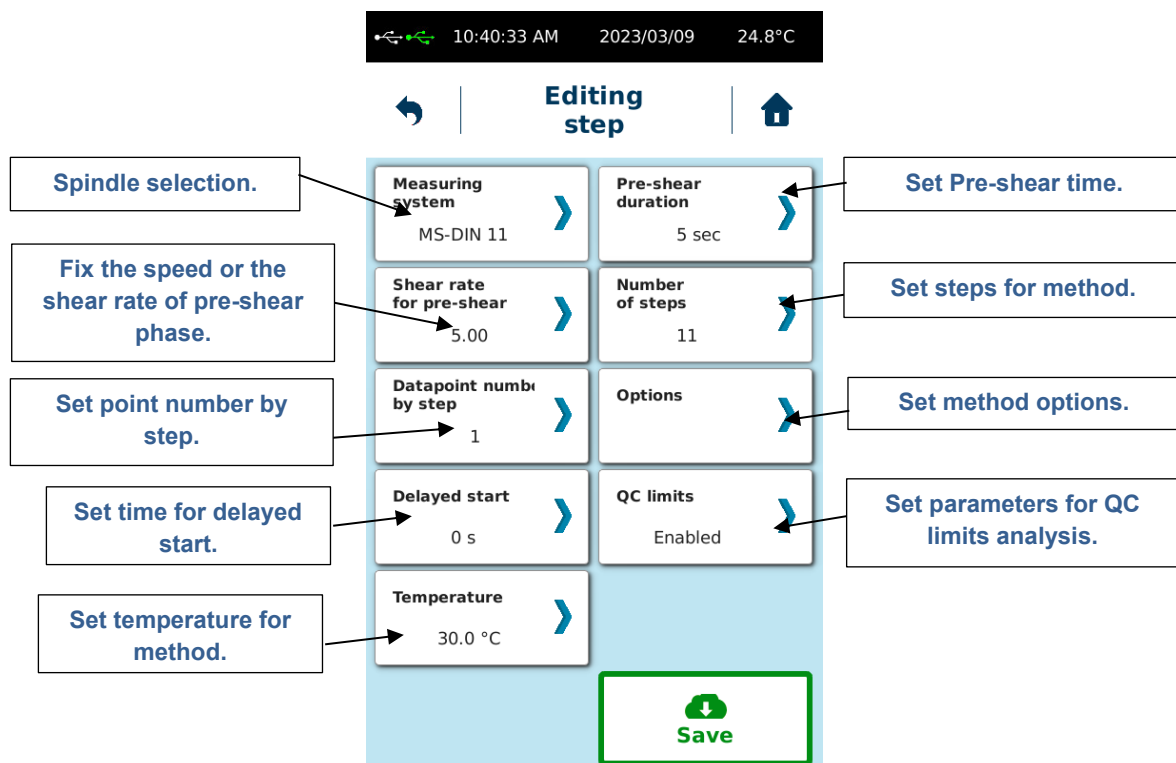

When creating a new method, the next buttons is activated after your validations progresses.

According to the selected mobile, the instrument will offer you to fix the shear rate (s^{-1}) instead speed (rpm) as that is the case for MS DIN or MS SV measuring systems. To force rotation speed in rpm, please read section 2.6.9 of this user manual.

The "Delayed start" function allows you to set a waiting time before the measurement. This time will be deducted as soon as you launch the measurement (see section 2.3).

The "Temperature" button is only present if the function has been activated in the instrument. This is the case only for models N240251, N240257, N240601, N240801 and N240901. By default, this function is not accessible. See section 3.2 to set the temperature of your methods with other models.

The "QC limits" function is identical as defined in paragraph 2.8.1.1.

When you select the "Number of steps" button, the instrument displays a new view.

The screenshot shows the 'Step editor' interface on a mobile device. At the top, the status bar displays the time 11:11:16 AM, the date 2023/03/09, and the temperature 24.5°C. Below the status bar, there are navigation icons: a back arrow, the text 'Step editor', and a home icon. The main content area is a list of steps, each with a checkbox, a step number, a duration, and a shear rate. Step 1 is selected, and its details are shown in a modal view below the list. The modal view has four sections: 'Add new step', 'Delete step', 'Edit duration', and 'Edit value'. Callouts with arrows point to these sections and the list items, explaining their functions.

Step	Duration	Shear Rate
1	5 s	5.00 s^{-1}
2	5 s	10.00 s^{-1}
3	5 s	20.00 s^{-1}
4	5 s	30.00 s^{-1}
5	5 s	40.00 s^{-1}
6	5 s	50.00 s^{-1}
7	5 s	60.00 s^{-1}
8	5 s	70.00 s^{-1}
9	5 s	80.00 s^{-1}
10	5 s	90.00 s^{-1}

Callouts:

- Allows you to select the step for copy, edit or delete.
- To delete selected step.
- Allows you to change the speed or shear rate of selected step.
- Allows you to copy selected step and then add it after it.
- Allows you to modify the selected step duration.

Once changes have been done, you can use the button to return to the previous screen. The instrument will display the new number of steps.

The "Options" function allows you to integrate a rheological analysis or a temperature setting condition as described in the following view.

Select this function if you want the instrument to chain the same succession of steps but in the opposite direction.

Allows a rheological analysis to be carried out on the measurement results.

Allows you to indicate on which step you wish to perform a rheological analysis. These buttons are disabled if "Use All Points" is selected.

Allows you to wait for the temperature defined in the method to be reached before starting the measurement.

Allows you to use all measuring points for your rheological analysis.

Allows you to use the points generated by the steps used in the opposite direction. This option is only available if you have checked "Decreasing ramp"

The "Start at temperature" option is only interesting if temperature control is activated on your instrument (only for models N240251, N240257, N240601, N240801 and N240901).

The "Decreasing ramp" option is interesting if you want to use the step method to generate a flow curve. This descending part will be carried out following the first succession of steps. The term "Decreasing" means that the instrument will decrease the speed or the shear rate. It is therefore important that, during the first succession of stages, the speed or the shear rate are increasing.

2.8.1.3 Ramp method

When you select the ramp method, you will get the following view.

Spindle selection.

Set Pre-shear time.

Set initial speed or shear rate.

Set time of increasing ramp.

Set method options.

Set temperature for method.

Set datapoint number of increasing ramp.

Fix the speed or the shear rate of pre-shear phase.

Set final speed or shear rate.

Set hold time (plateau).

Set time for delayed start.

The ramp method includes an increasing ramp, a plateau and a decreasing ramp by default. The "Datapoint number" and "Ramp time" parameters will be used for both ramps. The speed or shear rate of the decreasing ramp will be reversed from the increasing ramp. If you want only increasing ramp, you need to set the hold time to 0s and select "Single ramp" in the method options.

When creating a new method, the next buttons is activated after your validations progresses.

According to the selected mobile, the instrument will offer you to fix the shear rate (s^{-1}) instead speed (rpm) as that is the case for MS DIN or MS SV measuring systems. To force rotation speed in rpm, please read section 2.6.9 of this user manual.

The "Delayed start" function allows you to set a waiting time before the measurement. This time will be deducted as soon as you launch the measurement (see section 2.3).

The "Temperature" button is only present if the function has been activated in the instrument. This is the case only for models N240251, N240257, N240601, N240801 and N240901. By default, this function is not accessible. See section 3.2 to set the temperature of your methods with other models.

The "Options" function allows you to integrate a rheological analysis or a temperature setting condition as described in the following view.

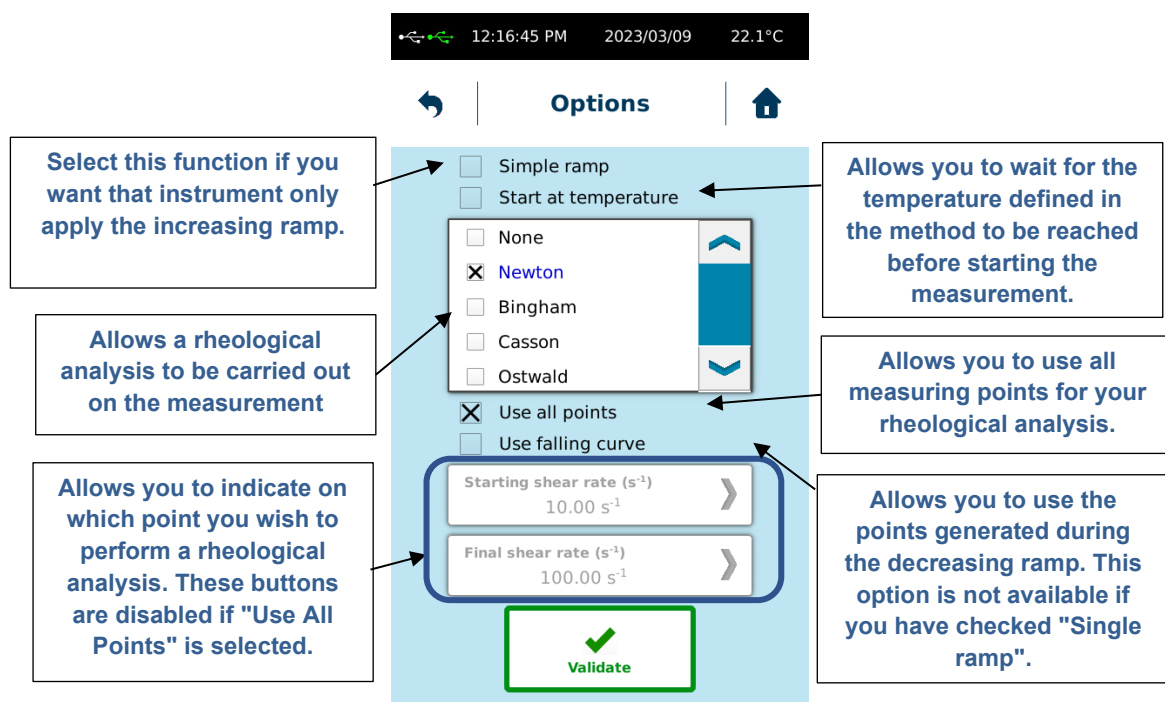

The "Start at temperature" option is only interesting if temperature control is activated on your instrument (only for models N240251, N240257, N240601, N240801 and N240901).

The "Simple ramp" option is interesting if you only want to apply the increasing ramp.

The rheological analysis is applied by default on the increasing ramp. If you want to apply this analysis on the decreasing ramp, be sure to select "Use falling curve".

2.8.2 Edit program

This function allows you to modify an existing method. Select a method by checking the corresponding box. The "Edit program" function becomes active and allows you to navigate through the parameters in the same way as described in paragraph 2.8.1. After modifying the method, you have the option of saving it under another name or overwriting the existing method name.

2.8.3 Delete program

This function allows you to delete a method from the instrument memory. Select the method concerned by checking the corresponding box. You can delete them all at the same time by selecting the "Select all" function.

2.9 Temperature setpoint menu

This function is available in the main menu.

As described in paragraph 2.3 and 2.8, this function is only available if your device is delivered with a temperature control that can be controlled (only for models N240251, N240257, N240601, N240801 and N240901). By default, this function is inactive. See section 3.2 to set the temperature of your methods with other models.

This mode does not allow temperature ramps to be carried out via the instrument. For this type of method, the use of RheoTex software is required.

Contrary to the use of the setpoint in a measurement method (see section 2.8), the use of this function is useful for controlling the temperature setting unit without performing a measurement. So, you can precondition your sample to the right temperature before starting the measurement.

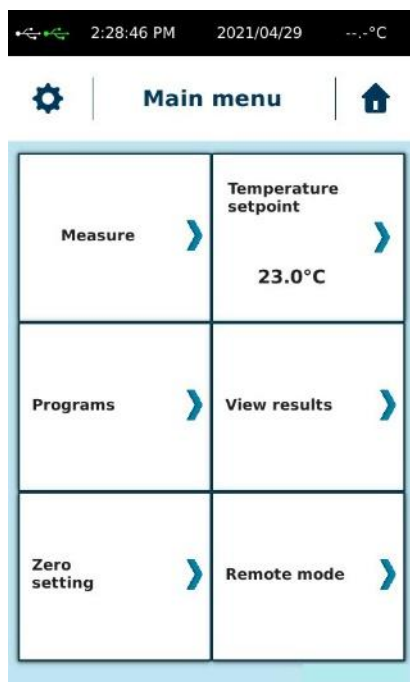

3 MEASURING WITH YOUR DEVICE

This section will show how use the different measuring system with your device.

Instrument need to be installed before next section of this manual (see section 1.5).

3.1 Installation of measuring system

The coupling of the RM 200 CP4000 PLUS is of type AC 265. It is a system allowing the insertion and the quick fixing of the measuring mobiles. A simple vertical action of the ring upwards (release) or downwards (locking) allows easy manipulation of the measuring tool.



For a good rotation please respect the alignment of arrow on measuring cone and arrow on the coupling.

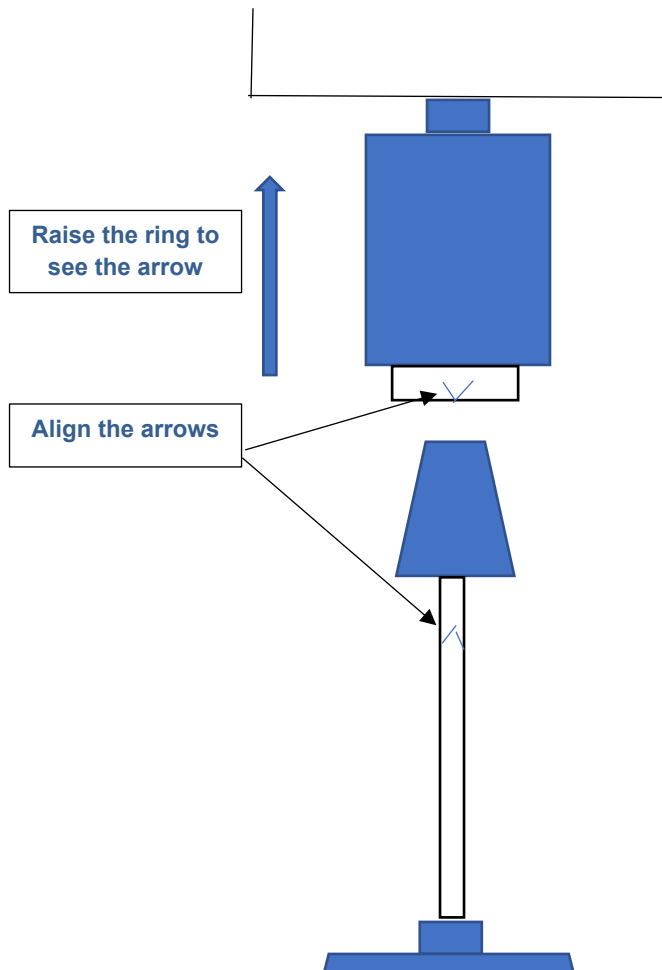

Models N240256 and N240257 allow the use of cylindrical rotors MS-DIN and MS-SV as well as vane rotors MS-VANE (in an MB-DIN cup). The AC265-BAYONET adapter is supplied with your device. It allows the use of bayonet coupling pins like MS-DIN, MS-SV and MS-VANE. To use it, you must unscrew the small screw of this adapter, insert the bayonet side of the pin inside the hole and lock it with the tool provided. Please do not insert it too much and check that only the conical part of the bayonet pin shaft is visible. These models contain an adapter (see section 1.1) to be fitted before inserting the MB-DIN or MB-SV cups.



3.2 Temperature settings

This section only applies to models N240250, N240256, N240600, N240800 and N240900. For other models, please refer to section 2.9.

The value read on this display is the set temperature. The value read on the screen of the RM 200 CP4000 PLUS is the actual value of temperature.

To change the setpoint, press the arrows to adjust the desired temperature, the new setpoint will be taken into account after a few seconds without validation

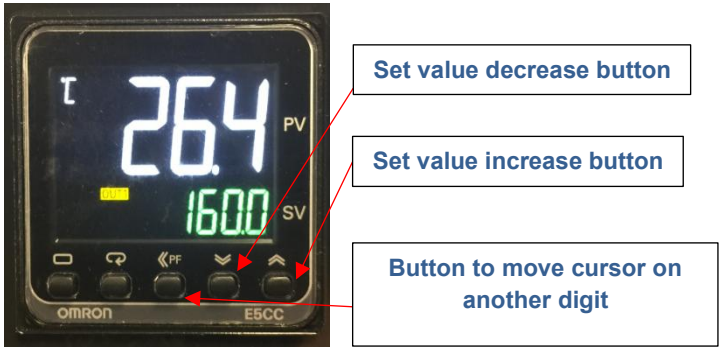

3.3 Gap settings

Gap adjustment is required before each measurement. It allows you to realize the contact position (also called zero gap), to memorize the measuring position and to place the geometry at this position in order to realize your measurement.

Elevator functions are available when you select the "Measure" tab on the main screen. Then you are in Measure windows, you can see settings for gap.

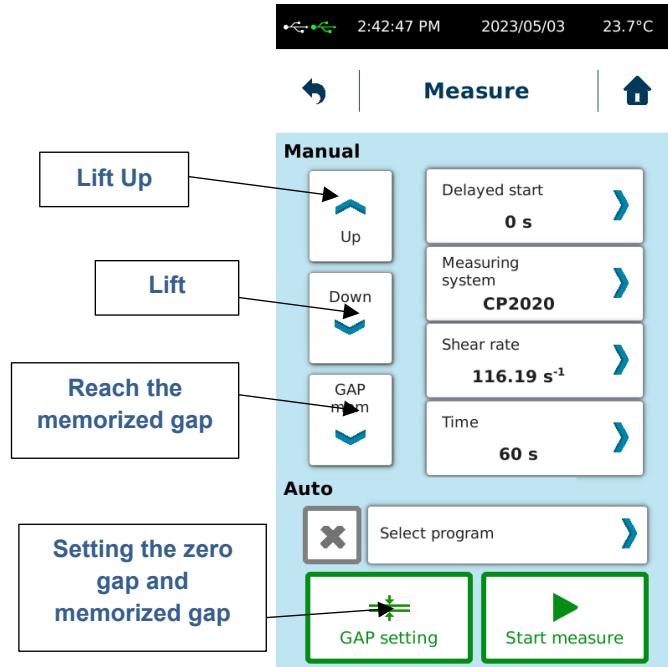

Each Measuring system can have its own positioning gap for measurement. To set this memorized gap or to make zero gap, you have to click on "GAP setting".

Your RM 200 CP4000 PLUS is equipped with an automatic lift device. Setting the zero gap is very important for the measuring position to be as ideal as possible. This adjustment must be done with the mobile, without sample, at the measuring temperature and be renewed temperature is different. Please also clean correctly upper and lower part before you start this procedure.

The first step is to select the mobile you have chosen for your measurement by pressing "Measuring System" (see screen on previous page). Indeed, if you change mobile later, the zero gap will no longer be valid and must be redone for the new measuring system you have selected. In the case of a measurement using a program (see section 2.3.2), it is preferable to load the protocol by selecting it before setting the zero gap. You must then warm up your measuring platform (see section 2.9 or 3.2 according model). You must also, especially if the set temperature is different from that of the room, put the measuring geometry on the lower plate to put it also in temperature.

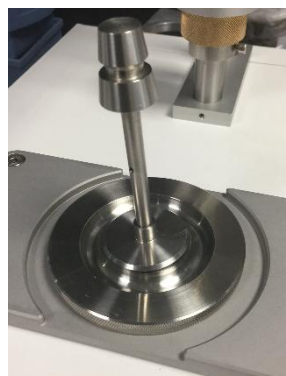

When the temperature is stabilized, you must leave your geometry at least 5 minutes in this position.

You can then fix the mobile on the measuring head (see section 3.1) before accessing the next step.

Select "GAP setting" to access this screen.



Enter the desired measuring position value by selecting "GAP value". For a measuring system with truncation (part number starting with 365...), this value must be set to 0.05mm. For a system without truncation, the position must be set to 0.01mm. For a plate geometry, the measuring position can be set between 0.150 mm and 2 mm.

Once the position has been memorized, press the "down" arrow to reach a position above 1cm from the base and select "Start" to reach the zero gap.

Once the zero gap has been found, the lift will automatically place the geometry at the memorized position and you will get this screen then zero will be done.



Once this step is completed, go to the "Measure" tab by pressing "Home" button and then "Measure". You can pull up the measuring head by pressing the arrow upwards, leaving enough space to place your product to measure. Then place your product as explained in paragraph 3.4 and then press the "mem GAP" button. The measuring head will go to the measuring position. Remove excess product, if necessary, by using a non-metallic soft tool with 90° angle.

You can make your measurement after that (see section 2.3).

3.4 MS CP/MS-PP

Cone-plane or plane-plane measurement systems standardized DIN / ISO 3219 (316L stainless steel). These systems make it possible to fix the shear gradient in order to carry out viscosity measurements or to obtain curves allowing the study of the flow behaviour, the flow threshold or the thixotropy. They are particularly suitable for the control or development of homogeneous products with a liquid aspect without particles. Choice of measuring system must be done according to the product to be measured. Favor wide diameters for low viscosities as shown on diagram below.

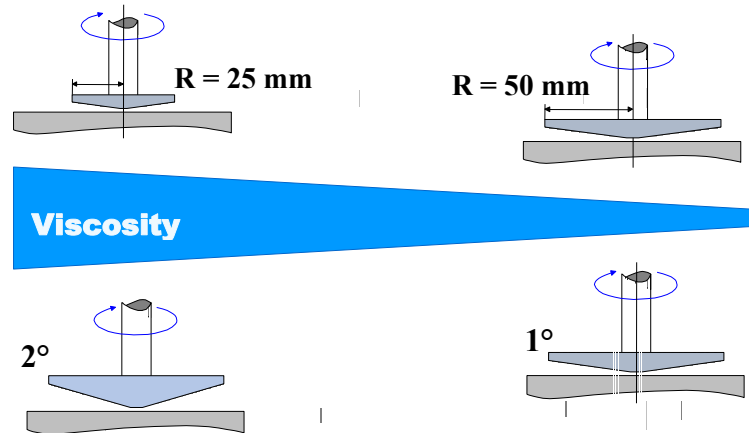

After installing the measurement geometry (see section 3.1), you must set the air gap as described in section 3.3. The amount of sample should be sufficient to completely fill the space between the cone and the bottom. In the case of a liquid sample, you can take the recommended volume for the dimensions of your cone-plane (see table below). For thicker samples, you need to draw enough with a spatula or similar tool.



Diameter (mm)	Angle (°)	Sample volume (ml)
10	0.5	0.0023
20	0.5	0.018
20	0.5	0.018
20	1.59	0.058
20	2	0.073
24	0.5	0.031
24	2	0.126
40	0.5	0.146
40	1.59	0.465
40	2	0.585
40	4	1.17
50	0.5	0.285
50	2	1.142
60	0.5	0.5
60	1	1
60	2	2
60	3	3











Sample volume for Plate measuring system depends on gap used. But filling need to be perfect as for cone.

You can now perform your measurement by going to paragraph 2.3. After the measurement is completed, please remove the geometry before cleaning it.

3.5 MS DINS (models N240256 and N240257)

Coaxial cylinders measuring systems according to DIN / ISO 3219 (316L stainless steel). These systems make it possible to set the shear rate in order to carry out viscosity measurements or to obtain curves to study flow behaviour, yield stress or thixotropy. They are particularly suitable for the control or development of homogeneous products with liquid aspect and with or without particles (size <200µm).

Please find below MS DIN items.

Name	Reference	
MK - DIN 1	112820	
MK - DIN 2	112821	
MK - DIN 3	112822	
MK - DIN 9	111875i	
CAP-DIN 1	112872	
CAP-DIN 2	112877	
CAP-DIN 3	112878	
MB-DIN 1 S Tube	112933	
MB-DIN 2 S Tube	112948	
MB-DIN 3 S Tube	112944	

Complete configurations include MB-DINXS tube, a MK-DIN cylinder and a cap.

Measuring system		Spindle	Cup	Cap
Designation	Part Number	Designation	Designation	Designation
MS DIN 11S	112809	MK-DIN1	MB-DIN1S	CAP-DIN1
MS DIN 12S		MK-DIN2	MB-DIN1S	CAP-DIN1
MS DIN 13S	112808	MK-DIN3	MB-DIN1S	CAP-DIN1
MS DIN 19S		MK-DIN9	MB-DIN1S	CAP-DIN1
MS DIN 22S	112815	MK-DIN2	MB-DIN2S	CAP-DIN2
MS DIN 33S	112814	MK-DIN3	MB-DIN3S	CAP-DIN3
MS DIN 23S		MK-DIN3	MB-DIN2S	CAP-DIN2

Here are the measuring ranges (viscosity in mPa.s **) of the existing MS DIN measuring systems:

Measuring system * Designation	Volume (ml)	Shear rate (s ⁻¹)**	Viscosity range LR Device (mPa.s)	Viscosity range B-ONE/FIRST/FIRST PRO/FIRST PRODIG (mPa.s)	Viscosity range RM100/RM200/DSR500 (mPa.s)
MS DIN 11S	27	1,29N	2,5 to 27K	25 to 0.44M	3 to 1M
MS DIN 12S	46	0,35N	11 to 145K	110 to 2.3M	18 to 5.5M
MS DIN 13S	22	0,15N	93 to 510K	920 to 8.3M	146 to 19M
MS DIN 19S	25	3,22N	0,8 to 10K	8 to 0.17M	1 to 0.39M
MS DIN 22S	22	1,29N	5 to 53K	40 to 0.86M	7 to 2M
MS DIN 33S	14	1,29N	20 to 265K	200 to 4.3M	34 to 10M
MS DIN 23S	36	0,19N	81 to 1M	810 to 17M	139 to 41M

M for million, K for thousand, N for rotational speed (rpm)

* Complete measuring system with spindle, cup and cap.

** These values are given when complete system is used.

MB-DINXS tubes are used with the MK-DIN cylinders and CAP-DIN. Their using facilitates cleaning and filling since they are shorter and therefore easier to access. On the other hand, they require the use of an accessory (Ref 114436) which guarantees a perfect centering of the cylinder in the tube.



The first step is to install the cap on the tube as shown in the photo below. Also check that the gasket is properly installed on the cap. The first insertion of the cap can be difficult. You must use some silicone grease to facilitate installation.

If necessary, remove the measuring plate in MS-CP/MS-PP.



Position the MB-DIN and MB-SV cup adapter. Insert it enough so that it does not protrude.

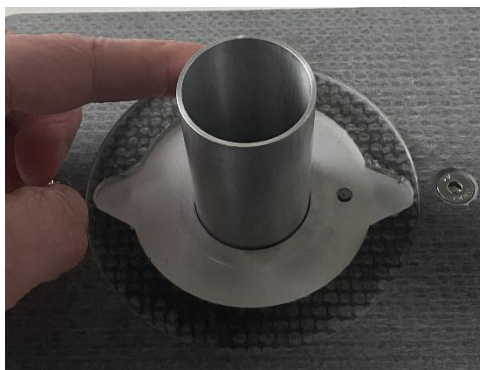

Then position the empty MB-DINS cup in the chamber.

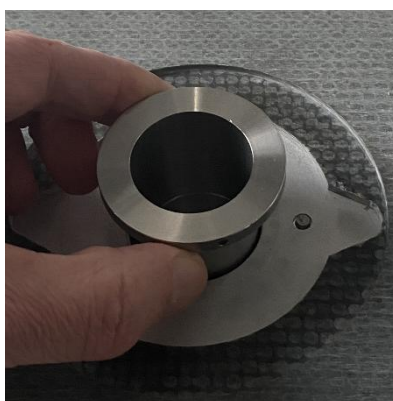

Install the AC265-Bayonet adapter on the MK-DIN mobile (see section 3.1). Insert the geometry into the AC265 coupling of the instrument (see section 3.1).



Choose simple measurement parameters or a program in the instrument (see section 2.3) to have access to the adjustment of the gap (see section 3.3). Make sure the selected measurement geometry is correct (i.e. MS-DIN11).

Slowly lower the elevator to insert the MK-DIN cylinder into the cup. Do not go to the bottom of the cup. Select "Gap setting", enter the "GAP value" at least 5mm (10mm is recommended for MS-DIN measurement geometries). Click on "Start". The instrument will search for the bottom of the cup as the contact position and then go back to the "GAP value" that you entered previously.

Raise the elevator completely to allow you to remove the MK-DIN cylinder and the MB-DIN cup.

You can then put the product to be measured in the cup. The required volume is indicated in the table on the previous page according to the system used. There is a level line in the tube (see photo below).



Put the MB-DIN cup back into the well of the instrument. Install the MK-DIN mobile again in the AC265 coupling. Descend with the elevator until the product to be measured is in contact with the MK-DIN mobile. Click on "GAP mem" so that the mobile reaches the position you have set before.

Once the installation is complete, you can take your measurement (see paragraph 2.3).

When your measurement is complete, it is advisable to remove the cylinder from the instrument shaft. The one will therefore rest in the tube. Raise the measuring head to the highest position using the lift. Then remove the tube containing the product and the cylinder, being careful if the temperature is high. You can then remove the MK DIN cylinder from the tube to clean it. Remove the cap from the DIN tube to clean it.

3.6 MS SV (models N240256 and N240257)

Measuring systems for low volumes (316L stainless steel).

These systems make it possible to measure products in small quantities by applying a shear rate up to temperatures of 70°C (according to models, see table).

Here are the available accessories:



**Measuring cylinder
MK-SV**



**Measuring chamber
MB-SV**

Please find below all item as MK-SV spindle and MB-SV chamber with viscosity range (mPa.s):

Measuring Cylinder		Compatible chamber		Volume (ml)	Shear rate (s ⁻¹)	Viscosity range LR Device (mPa.s)	Viscosity range B-ONE/FIRST/FIRST PRO/FIRST PRODIG (mPa.s)	Viscosity range RM100/RM200/DSR500 (mPa.s)
Designation	Item	Designation	Item					
MK-SV414	116114	MB-SV6R	116206	3	0,4N	44 to 5,8M	440 to 95M	73 to 219M
MK-SV415	116115	MB-SV7R	116207	4,4	0,48N	15 to 2M	155 to 33M	26 to 77M
MK-SV416	116116	MB-SV8R	116208	4,6	0,29N	39 to 5,2M	394 to 85M	66 to 197M
MK-SV418	116118	MB-SV13R	116213	7,5	1,32N	1 to 120K	9 to 1,9M	2 to 4,5M
MK-SV421	116121			8	0,93N	1 to 188K	14 to 3M	2 to 7M
MK-SV425	116125			10	0,22N	174 to 23M	1,7K to 377M	291 to 870M
MK-SV427	116127			12	0,34N	7 to 0,99M	75 to 16M	12 to 37M
MK-SV428	116128			13	0,28N	15 to 1,9M	147 to 31M	24 to 73M
MK-SV429	116129			13	0,25N	29 to 3,9M	294 to 63M	49 to 146M
MK-SV431	116131			11	0,34N	10 to 1,3M	100 to 21M	16 to 49M
MK-SV434	116134			11	0,28N	19 to 2,5M	194 to 41M	32 to 96M
MK-SVC	116002			13	0,43N	3 to 420K	32 to 6,8M	5 to 15M

M for million, K for thousand, N for rotational speed (rpm).

MK-SV cylinders are used with MB-SV13R, MB-SV6R, MB-SV7R and MB-SV8R chambers.

Whatever the measurement system model, the using is the same.

If necessary, remove the measuring plate in MS-CP/MS-PP.



Position the MB-DIN and MB-SV cup adapter. Insert it enough so that it does not protrude.

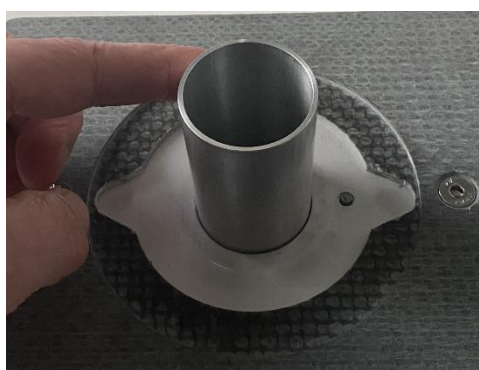

Then position the empty MB-SV cup in the chamber.

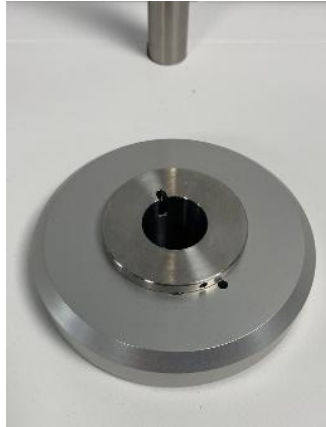

Install the AC265-Bayonet adapter on the MK-SV mobile (see section 3.1). Insert the geometry into the AC265 coupling of the instrument (see section 3.1).



Choose simple measurement parameters or a program in the instrument (see section 2.3) to have access to the adjustment of the gap (see section 3.3). Make sure the selected measurement geometry is correct (i.e. SV434).

Slowly lower the elevator to insert the MK-SV cylinder into the cup. Do not go to the bottom of the cup. Select "Gap setting", enter the "GAP value" at least 5mm (10mm is recommended for MS-SV measurement geometries). Click on "Start". The instrument will search for the bottom of the cup as the contact position and then go back to the "GAP value" that you entered previously.

Raise the elevator completely to allow you to remove the MK-SV cylinder and the MB-SV cup. You can then put the product to be measured in the cup. The required volume is indicated in the table on the previous page according to the system used. Put the MB-SV cup back into the well of the instrument. Install the MK-SV mobile again in the AC265 coupling. Descend with the elevator until the product to be measured is in contact with the MK-SV mobile. Click on "GAP mem" so that the mobile reaches the position you have set before.

Once the installation is complete, you can take your measurement (see paragraph 2.3).

When your measurement is complete, it is advisable to remove the cylinder from the instrument shaft. The one will therefore rest in the tube. Raise the measuring head to the highest position using the lift. Then remove the tube containing the product and the cylinder, being careful if the temperature is high. You can then remove the MK DIN cylinder from the tube to clean it.

3.7 MS-VANES (models N240256 and N240257)

Measuring spindles with blades (316L stainless steel).

These systems are ideal for viscosity measurement (value or curve) in control or development of all types of products even of very high viscosity with or without particles (size <5mm). They can be used for direct measurement in user's containers.



Here below are all available spindles with viscosity range (in mPa.s):

Designation	Part Number	Diameter (mm)	Length (mm)	Viscosity range LR Device (mPa.s)	Viscosity range B-ONE/FIRST/FIRST PRO/FIRST PRODIG (mPa.s)	Viscosity range RM100/RM200/DSR500 (mPa.s)
MK-V72**	120017	21,67	43,38	5,6 to 74K	56 to 1,2M	9,4 to 2,8M
MK-V73**	111108	12,67	25,35	28 to 370K	280 to 6M	46 to 13M
MK-V74**	111115	5,89	11,76	280 to 3,7M	2,8K to 60M	463 to 139M
MK-V75**	111111	8,026	16,05	111 to 1,4M	1,1K to 24M	185 to 55M
MK-V72/2**	111112	21,67	20	54 to 720K	540 to 11M	90 to 27M
MK-V72/4**	111113	21,67	10	80 to 1M	800 to 17M	133 to 40M
MK-V72-6P*	111121	21,67	43	30 to 400K	300 to 6,5M	50 to 15M
MK-VT105**	440105	5	10	430 to 5,8M	4,4K to 94M	726 to 218M
MK-VT2010**	442010	10	20	82 to 1M	820 to 17M	137 to 41M
MK-VT2020**	442020	20	20	12 to 150K	118 to 2,5M	20 to 5,9M
MK-VT3015**	443015	15	30	16 to 210K	160 to 3,4M	27 to 8M
MK-VT4020**	444020	20	40	7 to 90K	68 to 1,4M	11 to 3,4M
MK-VT5025**	445025	25	50	4 to 45K	34 to 730K	6 to 1,7M

M for million, K for thousand

* VANE 6 BLADES.

** These items can be used with tube MB-DIN1S (P.N.112933).

All data given in this table are given for information and can be changed according container use for measurement. For example, shear rate range show same data as for speed range of instrument. And most of the time, you will be able to use only speed for your viscosity measurement and not the shear rate.

The use of MS-VANES spindles is done exclusively with the MB-DIN1S measuring cup (112933). Please follow the instructions in section 3.5. The MK-DIN mobile being here replaced by the MK-Vanes mobile present in the table above.

4 VERIFICATION OF YOUR DEVICE

Your instrument is calibrated at the factory with an MS DIN11 measuring system (see calibration certificate) and a certified oil with a viscosity close to 1000 mPa.s. The verification method differs depending on the measurement system selected.

We inform you that the cone-plane geometries are never used internally for our checks and calibrations. Indeed, this type of geometry can lead to measurement errors due, for example, to the problems of gap filling, slippage, product ejection or wrong gap distance. You can nevertheless check your RM 200 CP4000 PLUS using your own geometry and a Newtonian standard oil of known and certified viscosity (preferably close to 1000 mPa.s).

When checking your instrument, it is important to calculate the maximum permissible error for the measurement. This error combines the precision of the instrument (1% of full scale for all mobiles and 2% with MS-CP) and the uncertainty in the viscosity value of the verification oil (generally 1% of the nominal value).

The full scale is calculated according to: Full scale viscosity (Pa.s) = (KTAU * M) / (KD * RPM).

Using the maximum torque of the instrument M (or the selected torque range, see section 1.4 or 2.6.8) for each rotation speed RPM and integrates constants KTAU and KD from the measurement geometries (see section 2.6.6).

Example: Mobile MK-CP5010 with a RM200 CP4000 PLUS at 50 rpm. We have: M = 30mNm (maximum torque of the instrument without torque range selection from section 2.6.8); KTAU = 30.6; KD = 6.

The full viscosity scale is therefore: $(30.6 * 30) / (6 * 50) = 3.06$ Pa.s.

2% of this value corresponds to: 0.061 Pa.s or 61 mPa.s.

For a check on a 1 Pa.s standard oil, the uncertainty on this value is 1% or 10 mPa.s.

The maximum allowed error is therefore: Precision from device + Incertitude from oil.

Here we have: $(0.061 + 0.01) / 6 = 0.071$ Pa.s or 71 mPa.s.

A measurement of this oil between 0.929 Pa.s and 1.071 Pa.s is therefore acceptable.

Here is the procedure to follow for your verification.

Viscosity measurement on a 1000 mPa.s standard silicon oil with a MS-CP measuring system.

Follow the instructions in paragraph 3.5 and 3.4 for placement.

- Perform a motor zero (see section 2.5).
- Warm up your geometry and the lower plane according to the procedure described in paragraphs 3.2 and 3.3.
- Install your measuring system (see section 3.1).
- Set Gap as described in section 3.3.
- Put standard oil on lower plate and lowering measuring cone in measuring position (see section 3.4 to check good filling of gap).
- Select a measurement method in manual mode by choosing a measuring time of 120s minimum and a shear of 100 s⁻¹ (see section 2.3).

Viscosity measurement on a 1000 mPa.s standard silicon oil with a defined DIN11S measuring system (models N240256 and N240257).

Follow the instructions in paragraph 3.5 for placement.

- Zero your instrument as described in paragraph 2.5.
- Install the MK-DIN 1 measuring spindle and the MB-DIN1S measuring bucket (see paragraph 3.5).
- Adjust the zero gap as described in paragraph 3.5.
- Remove the MB-DIN1 tube then fill it with oil and install it again on the base of the instrument.
- Place in measurement position as described in paragraph 3.5. Wait for temperature stabilization.
- Select the DIN11 measurement system on the instrument, select 50 s⁻¹ for the speed, select 30 seconds for the measurement time and start the measurement (see paragraph 2.3).

For both methods, the result at the end of the measurement must be within the tolerance due to the maximum tolerated error as explained previously. If the measurement is out of range, your instrument may require recalibration. Check if the error does not come from a wrong filling, a wrong zero adjustment, a wrong spindle rotation, or a wrong temperature value.



LAMY RHEOLOGY
11 A, rue des Aulnes
69410 Champagne au Mont d'Or (France)

Tel : 33 (0)4 78 08 54 06
Fax : 33 (0)4 78 08 69 44
contact@lamyrheology.com